

INTEGRATED PEST MANAGEMENT PLAN

FOR THE COUNTY OF RENFREW



Table of Contents

Statement of Goals/Rationale	4
Background History.....	5
Introduction	6
Hazardous and Toxic Plants – County of Renfrew	6
Regulatory Tools	7
Federal	7
Provincial.....	7
Municipal – Property Standards By-law.....	7
Weed Inspector Role.....	7
Integrated Pest Management Plan	9
General.....	9
Natural Resource Considerations	10
Setting Priorities.....	10
Site Prioritization.....	10
Prioritizing Within a Control Area	10
Regeneration vs. Restoration.....	11
Control Measures.....	12
Health and Safety Considerations.....	12
Manual Control	12
Mowing	12
Pulling.....	13
Pruning	13
Tarping	13
Cultural Control.....	13
Tillage	13
Burning.....	14
Chemical Control.....	14
Herbicide Application.....	14
Chemical Control Timing.....	14

Legislation Governing Pesticide Use	14
Health or Safety, Plants Poisonous to the Touch.....	15
Forestry Exception	15
Agriculture Exception.....	15
Foliar Spray	15
Wick or Wiper Applications	15
Biological Control	16
Disposal	17
Restoration.....	18
Types of Restoration	18
During Control.....	18
Mulching	18
Seeding	18
After Control	18
Soil Rehabilitation	18
Planting	19
Tracking the Spread of Wild Parsnip.....	20
Public Education.....	21
Acknowledgements.....	22
Appendices.....	23
A – Hazardous and Toxic Plants	
B – Noxious Plant Map	
C – Decision Matrices	
D – Health and Safety	
E – Distribution	
F – Clean Equipment Protocol	
G – Best Management Practices Documents, References/Additional Resources	
H – Public Service Announcement – Public Education	

Statement of Goals/Rationale

This Integrated Pest Management Plan (IPMP) provides guidance for managing hazardous and toxic plants for the County of Renfrew right of ways and property. Leadership for the production of this document was provided by the Public Works and Engineering and Development and Property Departments of the County of Renfrew. This IPMP was developed as a guidance document for the protection of public health, biodiversity, agricultural lands, infrastructure, crops and natural lands.

This IPMP is based on the most effective and environmentally safe control practices known from recent research and experience. It reflects the current provincial and federal legislation regarding pesticide usage, habitat disturbance and species at risk protection. This IPMP is subject to change as legislation is updated or new research findings emerge. This IPMP utilizes the Best Management Practices (BMP) developed by the Ontario Invasive Plant Council (OIPC) and its partners to facilitate the invasive plant control of individuals and organizations concerned with the protection of the natural and managed lands. They are not intended to provide legal advice, and are intended to be utilized in conjunction with all applicable legislation to address specific circumstances.

This document was prepared for the County of Renfrew.

Inquiries regarding this document can be directed to the:

County of Renfrew
9 International Drive
Pembroke, Ontario K8A 6W5
Phone: 613-735-3675 or Toll Free: 1-800-273-0183
Email: info@countyofrenfrew.on.ca

For more information on invasive plants in Ontario, visit:

www.ontario.ca/invasivespecies,
www.ontarioinvasiveplants.ca,
www.invadingspecies.com,
www.invasivespeciescentre.ca

Background History

Vegetation control along the roadsides is an important part of road maintenance. It ensures clear sight lines for signs, intersections and wildlife, promotes drainage and drying and prevents the establishment of trees, weeds and brush in the right of way. In 1991 the County of Renfrew established a “No Chemical” approach for the control of weeds and brush on County right of ways and directed that weed and brush control be maintained by mechanical methods (Resolution # CR-CC-91-02-29). In February 2000, County Council reviewed this resolution and Resolution # OP-CC-00-02-28 was passed upholding the “No Chemical” approach for the control of weeds and brush on County of Renfrew road right-of-ways. The current mowing practice does not kill noxious plants and may help spread the seeds along the roadside.

Following coverage in local and national media in 2015, the Area Weed Inspector and Forestry staff have received numerous inquiries from the public and media concerning wild parsnip and the County’s role in removing this noxious weed from private, County and Municipal Lands. Wild parsnip has been in the County for a number of years and is well established throughout the County. Public concern is high due to the plant’s health risks to humans.

The Operations Committee and the Development & Property Committee at their meetings in August 2015 directed County staff to prepare an analysis of control methods for Wild Parsnip. An analysis was completed and was presented to Committee by the Area Weed Inspector and the Manager of Operations.

On June 14, 2016 the Development & Property Committee recommended that staff prepare a policy to educate, map, mow and create an integrated pest management plan for noxious and hazardous plants on County owned properties.

Introduction

Hazardous and Toxic Plants – County of Renfrew

This plan and the accompanying Technical Guidelines/Resource Material have been developed to assist the County of Renfrew as guidance documents for control of Hazardous and Toxic plants. Two main species identified as the most prevalent are being targeted for control. Wild Parsnip and Poison Ivy form the base of the program, where plants such as Giant Hogweed are so rare in Renfrew County at this time that they can be dealt with one plant at a time.

Regulatory Tools

Federal

The County of Renfrew will not be utilizing Federal Regulation for additional control at this time.

Provincial

The County of Renfrew will not be utilizing Provincial Regulation for additional control at this time.

Municipal – Property Standards By-law

Under the *Building Code Act*, Section 7, municipalities are able to pass by-laws to address the presence of invasive plants. Municipalities may enact by-laws to control plants when there is a risk of negative impact to human health and safety.

Municipalities are also responsible for enforcing the *Weed Control Act* to reduce the infestation of noxious weeds. Municipalities can designate additional plants not listed on the Ontario Noxious Weed list as noxious within their own jurisdiction.

The County of Renfrew will not be utilizing a Municipal By-law for additional enforcement at this time.

Weed Inspector Role

The role of the Weed Inspector is to investigate complaints of noxious weeds and order and ensure the destruction of noxious weeds in accordance with the provisions of the regulations under the *Weed Control Act*.

Responsibilities include:

- Plan and implement a practical and relevant weed control program within their area when approached by the agricultural community.
- Coordinate action on noxious weed complaints from municipal inspectors with regard to highways, railways, public utilities, conservation authorities and other public bodies.
- Survey for noxious weeds on private and public lands and, if necessary, enforce the destruction of such weeds under the conditions laid down in the *Weed Control Act*, R.S.O. 1990, Chapter W.5. This shall be done in the most efficient and economical manner.

- Work with, and in support of, the municipal inspectors by reviewing their procedures and supplying them with all necessary printed material on weed control.
- Assist persons requesting weed identification.

Integrated Pest Management Plan

General

Controlling hazardous and toxic plants before they become established will reduce its impacts on human health, biodiversity, the economy and society.

It is important to use a control plan that incorporates integrated pest management principles. This means using existing knowledge about the pest species and its surrounding environment to prevent and fight infestations and may require more than one type of control measure to be successful.

Once toxic plants are confirmed at a location, a control plan can be developed based on infestation size, site accessibility, potential for spread and the risk of environmental, economic or social impacts. Site specific conditions such as native plant diversity, wildlife usage and water table fluctuations should also be considered when developing control plans. A detailed assessment of each site is imperative before starting control efforts ensuring utilization of proper methods and timing to minimize negative impacts.

After an infestation of a target species is confirmed, the County of Renfrew will first focus their efforts on preventing spread by removing isolated plants and small populations (satellite infestations) outside the main infested area. Early action can significantly reduce the cost of control.

With large infestations and limited time and resources, the County of Renfrew will develop a feasible, long-term strategy with the following considerations:

1. Educate the public on hazardous and toxic plants.
2. Attempt removal of outlying populations (isolated plants or satellite populations) first, to prevent further spread.
3. Concentrate on high-priority areas such as the most productive or sensitive part of an ecosystem or a favourite natural area.
4. Dedicate a certain time each year to control efforts, where possible as a joint effort with neighboring landowners/land managers.
5. Plan to replant native ground cover including erosion resistant treatments to minimize soil disturbance and re-infestation of the invasive species once the target species population is eradicated or under control. This will help jump-start natural succession and increase biodiversity in the area.

6. Follow-up monitoring and mapping is crucial to remove seedlings that may sprout after initial control efforts.

A number of natural resource considerations should be applied before starting control plans, including species at risk and habitat disruption.

Natural Resource Considerations

The County of Renfrew will ensure that this program will comply with all relevant laws, including the *Endangered Species Act* (ESA). If protected species or habitats are present, an assessment of the potential effects of the control project will be required. The County of Renfrew will consult with the applicable Ministry in charge of Natural Resources in the creation and delivery of control plans. If controlling plants in riparian areas, impacts to shoreline health will also be considered.

Setting Priorities

When creating management plans, the County of Renfrew will make the most of resources by prioritizing invasive species control. The County of Renfrew will utilize the following process to prioritize sites and areas within sites for control of target species.

Site Prioritization

1. Protect areas where target species are absent or nascent.
2. Protect rare species and communities, including federal, provincial and regionally listed rare species and communities.
3. Protect important habitats and land values (e.g. agricultural industry).
4. Cost and effort: Will the area where the target species has invaded require resources for restoration or can it be left to regenerate naturally? (Note – it is usually recommended to restore control areas to make them more resilient to future invasions).

Prioritizing Within a Control Area

1. Focus on large blocks of pristine areas and keep them free of invaders.
2. Control small, younger, outlier (satellite) populations first.
3. “Defragment” the boundaries of invaded areas by removing outlying plants.
4. Reverse the invasion, expand the pristine areas outward.

It is crucial to prioritize control by determining where the satellite populations are, and eradicating those before they join up with larger populations.

Refer to the “prioritization flow chart” in Appendix “C” Decision Matrices for assistance in the development of the control plan.

Regeneration vs. Restoration

The County of Renfrew will consider the following factors:

- **Level of Disturbance at the Site**

What is the level of disturbance at site? Was it a heavily invaded site (i.e. a lot of disturbance was caused when things were removed)? Will it continue to be disturbed (i.e. through trail use and management)?

- **Species Biology**

What is the biology of the species removed and is there a seed bank to consider (i.e. there will always be a seed bank to consider when dealing with Wild Parsnip)?

- **Re-invasion Risk**

Are there species in the area that could re-invade the site from certain pathways of introduction, such as nearby trails or watercourses?

- **Existing Native Vegetation**

What native vegetation is left? How long before it regenerates by itself? Does it need help?

In reviewing the above conditions at the site, if it is most likely that the site will be re-invaded before it has a chance to regenerate on its own, restoration will be needed to reduce the risk of re-invasion.

Refer to the “[Restoration Methods](#)” section of this document.

Control Measures

Controlling target species before they become well established will reduce their impacts on biodiversity, agriculture and society. Therefore time is of the essence to develop and maintain a plan and program.

Health and Safety Considerations

Regardless of the management option, the County of Renfrew will enforce that protective equipment will be utilized during the development and delivery of the plan.

The toxins in the target species can cause serious reactions, including reddening, blistering and ulceration of the skin and inflammation. The toxins of the target species react through different processes, chemical reactive versus photo reactive. Chemical reactive toxins respond without requiring a catalyst such as sunlight (i.e. Poison Ivy). The photo reactive toxins can cause severe burns that occur if the sap contacts the skin and is then exposed to sunlight causing phytophotodermatitis. Symptoms can occur within 48 hours and scarring and pigmentation can last for weeks and even months.

The general public and County of Renfrew staff are at risk of exposure to the toxins, therefore the development of a plan and program lower the risk.

Manual Control

Because the target species reproduce by seed, the reduction or prevention of seed production is an important goal in the County of Renfrew program.

MOWING

The County of Renfrew control program will make every effort to schedule mowing to be completed at the appropriate time as it is the most effective way of controlling larger infestations. The goal of the County of Renfrew program will be to mow infested areas as soon as flower stalks appear, but before seeds set to prevent seed production. Poorly timed mowing can actually increase Wild Parsnip populations. Mowing, in July or August for example, can disperse the seeds. Mowing when the umbel starts to flower (May-June) can be effective at reducing fruit production. This is because energy reserves then have to go towards stem production instead of flower and seed production. Mowing can also allow sunlight to reach rosettes that are lower than the mower blades, allowing them to grow quickly. This control method needs to be repeated for several seasons for it to be effective.

The County of Renfrew will utilize the Clean Equipment Protocol to clean equipment used in the control program (Mower) provided by the Ontario Invasive Plants Council.

PULLING

For small infestations, the County of Renfrew will consider removing target species using a shovel as hand pulling is not recommended due to the risk of exposure to the toxic sap contained in the plant's leaves, stems and roots. The County of Renfrew will endeavor to schedule this method of control at the optimal time as best times for removing the plant are right after a rain when the ground is soft or during times of drought (when the taproot shrinks). Severing the taproot with a hoe or other sharp object, before the plant goes to seed, 2.5-5 cm below the soil can also be effective. Again, it is easiest in moist soil, and in the spring, when the taproot is a manageable size.

This method will be used as a secondary method as a result of the risk to workers and the high level of labour resources required.

The County of Renfrew will be monitoring sites to check for re-sprouts and missed plants.

PRUNING

The County of Renfrew will consider pruning as a control method where and when appropriate. If a plant is flowering, herbicides are not effective and control methods should focus on carefully removing the flower heads. This method will be used as a secondary method as a result of the risk to workers and the high level of labour resources that would be required.

TARPING

The County of Renfrew will consider tarping as a control method where appropriate. This method employs covering the ground with a tarp and may be used in conjunction with other control methods.

For example, after digging or mowing the target species, the area can be covered with black plastic, smothering growth of new plants. The plastic would be left in place for at least one full growing season. Once the plastic is removed, replanting and restoration would be undertaken.

CULTURAL CONTROL

Wild Parsnip can be outcompeted by other plants, mostly in high-quality prairie settings and only if the growth of native plants is aggressive enough. Since the plant ecology in Renfrew County is not conducive to this method of control, it will be unlikely that this approach will be utilized unless special circumstances arise.

TILLAGE

In agricultural settings where tillage is used, invasive plants are not usually an issue. Since the County of Renfrew does not engage in this activity it will be unlikely that this approach will be utilized unless special circumstances arise.

BURNING

Burning does not control Wild Parsnip populations directly, but periodic burning can encourage the growth of native fire tolerant species, which can out compete target species. Caution must be taken if burning an area containing toxic plant species. Burning could release sap into the air, potentially causing severe reactions to people downwind. The County of Renfrew does not plan to utilize this method of control at this time.

Chemical Control

HERBICIDE APPLICATION

The County of Renfrew shall utilize herbicides in accordance with all manufactures' directions and applicable legislation in the delivery of this program.

Ontario Pesticides Act and Ontario Regulation 63/09 are available at www.ontario.ca/laws or contact the Ontario Ministry of the Environment and Climate Change at www.ontario.ca/ministry-environment-and-climate-change.

For an up-to-date list of herbicides labeled for target species control, the Pest Management Regulatory Agency's at the Health Canada website www.pmra-arla.gc.ca will be consulted.

To determine if a federally registered herbicide is also classified for use in Ontario the County of Renfrew will use the most recent version of approved list through the Canadian Government Environmental Ministry Registry Pesticides Classification Database at www.ontario.ca/page/classification-pesticides.

Anyone using a pesticide is responsible for complying with all federal and provincial legislation. Most non-domestic (i.e. commercial, restricted, etc.) herbicides can only be applied by licensed exterminators. The County of Renfrew shall utilize licensed exterminators, whether through commercial contractors and/or in house staff based on industry standard analysis.

CHEMICAL CONTROL TIMING

The County of Renfrew will plan the use of any chemical products in conjunction with the species specific characteristics, chemical use guidelines and legislation. In general the most effective time to apply a systematic herbicide is in the early spring on newly bolted plants (right after the flower stalks have grown) or rosettes and in the late fall on rosettes. The County of Renfrew avoids treating species in full flower which would not prevent setting of the seeds and is not recommended.

LEGISLATION GOVERNING PESTICIDE USE

The *Ontario Pesticides Act*, Sections 7, 7.1 and 35, and Ontario Regulation 63/09 provide natural resources, forestry and agricultural exceptions which may allow chemical control of

invasive plants on private property. Other exceptions under *the Act* include golf courses and for the promotion of public health and safety.

HEALTH OR SAFETY, PLANTS POISONOUS TO THE TOUCH

The exception for plants that are poisonous to the touch allows the use of pesticides to control plants such as Poison Ivy and Wild Parsnip. Under this exception, only the use of herbicides listed in Class 10 are allowed for use to control plants poisonous to the touch. A pesticide license(s) for the County of Renfrew staff or for a hired contractor would be required.

FORESTRY EXCEPTION

A forest is defined as a treed area of land that is one hectare in size or larger. Class 9 pesticides may be used in a forest for the purposes of harvesting, renewing, maintaining or establishing a forest, protecting forest resources derived from a forest, and accessing a forest for these purposes under the forestry exception.

The control of plants poisonous to the touch fall under the forestry exception; a Forestry Class of land exterminator license would be required to use commercial pesticides in a forest. The County of Renfrew would qualify under its forestry discipline.

AGRICULTURE EXCEPTION

The County of Renfrew would not qualify for this exception at this time as it does not engage in applicable activities.

FOLIAR SPRAY

This type of application employs the use of spray equipment either by hand or vehicle mounted depending on the area size to be treated. The County of Renfrew will consider this type of control for infestations that meet the option selection tool. Generally the spray is applied only until the target species' leaves are covered in herbicide. All efforts will be made to avoid over spraying to the point that the herbicide is dripping off the leaves or on adjacent areas. This will be achieved through the monitoring of the environmental conditions (wind) at control time and through the use of experienced contracted services or trained certified staff.

WICK OR WIPER APPLICATIONS

This type of application employs the use of chemical wetted media (rope, cloth, etc.) that wipes (contacts) the plant thus transferring the chemical from the media to the plants and can be by hand or vehicle mounted depending on the area to be treated, terrain, etc. The County of Renfrew will consider this type of control for infestations that meet the option selection tool. This method employs that the herbicide be applied directly to the leaves of target species, using a wick or wiper applicator. This is an alternative to foliar spray where

there are concerns over drifting herbicides and impacts to surrounding species or the natural environment.

Herbicide treatments need to be repeated annually until the seed bank is depleted. This method will be used as a secondary method as a result of the risk to workers and the high level of labour and material (mulch) resources that would be required.

BIOLOGICAL CONTROL

Biological control is the use of an herbivore, predator, disease or other natural enemy to reduce established populations of invasive species. Most invasive species have no natural enemies in their new habitats. Biological control aims to re-establish an ecological balance between the invasive species and its natural enemies by selecting highly host-specific natural enemies from the country of origin, and moving them to the country where the invasive species is a problem. This is only done after extensive host-range testing in the country of origin or quarantine, to ensure that the potential biocontrol agent is host-specific to the targeted invasive species. This method has been used successfully for invasive plants in North America, including Purple Loosestrife (*Lythrum salicaria*), Leafy Spurge (*Euphorbia esula*), Diffuse Knapweed (*Centaurea diffusa*) and St John's Wort (*Hypericum perforatum*).

There are many species which will feed on Wild Parsnip, but most do not cause enough damage to the plants to provide control. Deer and other large mammals will eat Wild Parsnip and small mammals and upland birds eat the seeds. A number of insects consume Wild Parsnip, but "sequential flower development" means that when Wild Parsnip is damaged, the plant will compensate by producing more flowers.

One of the challenges associated with implementing a host-specific biocontrol for Wild Parsnip in Ontario, is that the host-specific organism will not only feed on Wild Parsnip, but also cultivated parsnip, which could impact agricultural operations.

Based on the above, this option is not realistic for the County of Renfrew to consider at this time.

Disposal

The County of Renfrew will dispose of plants removed from the ground in an appropriate manner. They will not be burnt due to the health risks or composted due to the likelihood of spreading the infestation to other areas. The plants will be placed in black plastic bags and left in direct sun for at least a week and then disposed of at an approved landfill.

Restoration

The County of Renfrew recognizes that restoration can be a critical aspect of pest management. Site restoration will result in a healthier ecosystem more resistant to future invasions. The County of Renfrew program will include a monitoring component for all restoration activities to ensure native species are becoming established, and to continue removal of invasive plants that remain onsite.

Types of Restoration

During Control

MULCHING

Mulching sites immediately after invasive species control (i.e. manual or chemical control of Wild Parsnip) may aid in the recovery of native species and prevent immediate re-colonization by other invaders. Mulching reduces light availability, allowing more shade-tolerant native plant species to germinate and colonize the gaps left by the Wild Parsnip removal.

SEEDING

Seeding an area with an annual cover crop or native plant species, immediately after management activities, will be useful to prevent the establishment of new invasive species. This will give desirable native species the chance to establish themselves. For example Ministry of Transportation (MTO) Seed Mix or other approved industry standard.

After Control

SOIL REHABILITATION

The County of Renfrew will establish a sustainable program to support natural environment health through the intelligent use of the existing biomass. Target species often change soil chemistry (i.e. Wild Parsnip) by adding nitrogen to the soil. The soil may no longer support native plant species, and may be better suited to other invaders moving in. Replenishing the mycorrhizae in the soil after all invasive species control has been completed will help to reduce any effects and restore soil conditions to encourage native species to re-grow. Growth of mycorrhizae fungi can be encouraged by using leaf mulch, logs and sticks (to provide food and protective cover for the fungi) and reducing soil compaction. The County of Renfrew's right-of-ways' environment contains a natural source material for the re-establishment of the natural fungi and native plant species. Commercial mycorrhizae products are also available for purchase in Ontario; however with the sustainable quantity

of biomass available naturally, the use of commercial products could be minimized or eliminated.

PLANTING

The County of Renfrew will consider planting or relocating existing stock in specific areas for soil stability and transitional areas to support the native environments in control areas. Planting larger native species stock (potted, etc.) will help other native species recover and outcompete invasive seedlings. The County of Renfrew will wait until all management is complete before doing a large stock re-planting, as it may be difficult to distinguish between newly planted native species and invasive seedlings, therefore minimizing the risk to valuable expended resources.

When completing planting at control sites, the County of Renfrew will consider the impacts to the habitat and the most effective way to support the natural environmental cycles. (i.e. consider earthworm impacts (little to no leaf litter) and light availability (have any trees recently been removed which have opened up the forest canopy?)). This program will account for these types of environmental changes when choosing plant species for restoration.

Tracking the Spread of Wild Parsnip

Several reporting tools have been developed throughout the Province of Ontario to assist the public and resource professionals to report sightings, track the spread, detect it early, and respond quickly. The County of Renfrew will create a mapping strategy to track the program outcomes and will include a public input reporting mechanism.

The following links are existing reporting tools that serve as sample frameworks:

1. Early Detection & Distribution Mapping System (EDDMapS) is an on-line reporting tool where users can view existing sightings of invasive species in Ontario including Wild Parsnip, and document their sightings. This free tool is available at <http://www.eddmaps.org/ontario>.
2. The toll free hotline number for Ontario's Invading Species Awareness Program is 1-800-563-7711 and website (www.invadingspecies.com), are available for individuals to report sightings verbally or on-line.

Public Education

The County of Renfrew considers public education a cornerstone of the program.

A comprehensive public education program will be developed utilizing the approach below:

- Yearly notices about the safety related issues with toxic plants in the environment.
- Public consultation on area specific plans including the proposed control methods. This approach will allow the opportunity to educate.

For a sample of a Public Service Announcement/Public Education release please refer to Appendix “H”.

Acknowledgements

Reviewers:

Steven P. Boland, Director of Public Works and Engineering, County of Renfrew
James Hutton, Chief Administrative Officer, County of Renfrew

Document Creation/Compilation by:

Richard Bolduc, A.Sc.T.
Manager of Operations
Public Works and Engineering Department
County of Renfrew

Jason Davis
Forestry and GIS Manager
Development and Property Department
County of Renfrew

Appendices

Appendix A – Hazardous and Toxic Plants – County of Renfrew

Appendix B – Noxious Plant Map

Appendix C – Decision Matrices

Appendix D – Health and Safety

Appendix E – Distribution

Appendix F – Clean Equipment Protocol

Appendix G – Best Management Practices Documents References/Additional Resources

Appendix H – Public Service Announcement/Public Education

Appendix “A”

Hazardous and Toxic Plants

Technical Guidelines

(Best Management Practices & Resource Material)

for the

Integrated Pest Management Plan

COUNTY OF RENFREW

HAZARDOUS AND TOXIC PLANTS – COUNTY OF RENFREW

Wild Parsnip

Parsnip is a plant that is familiar to many of us in its culinary form. Wild Parsnip is a member of the Apiaceae family; the same family as culinary plants such as carrot, celery, celeriac, fennel, anise, caraway, chervil, coriander, dill, lovage, parsley and weed plants such as Wild Carrot, Giant Hogweed, and Poison Hemlock.

It was likely brought to North America by early European settlers who grew it as a root crop. Wild populations are thought to be a result of escaped cultivated plants. By 1943 there were reports of Wild Parsnip growing wild in every Canadian province. By the 1970's its range included the territories (with the exception of the area now known as Nunavut). Other common names include bird's nest, common parsnip, poison parsnip, and hart's eye.

Wild Parsnip grows quickly, forming dense stands, especially in disturbed areas. Wild Parsnip reproduces only via seed (sexual reproduction) and seeds are carried and spread to new areas by wind and water, and on mowing or other equipment. It can become a problem particularly in abandoned agricultural areas.

One plant produces, on average, 975 seeds with a median dispersal distance of 3 metres (lighter seeds are carried further than larger, heavier ones). Growth of the plant begins in the spring and lasts through early autumn. In its more southern range, the plant may keep some of its leaves all winter.

The seeds of Wild Parsnip contain chemicals called furanocoumarins, which along with deterring herbivores from eating the plant, can also cause a burn-like rash (phytophotodermatitis) in people and livestock. This is the same toxin present in Giant Hogweed (*Heracleum mantegazzianum*) as well as several other members of the carrot (Apiaceae) family.

The plant takes two or more years to mature, and spends its first year (or more) as a basal rosette growing close to the ground. During this first year as a basal rosette, the plant stores its reserves in a large taproot. Once the plant matures, it flowers, and then dies.

Wild Parsnip is a tall “monocarpic perennial”; meaning it is a plant that matures, flowers and fruits once, and then dies.

Plant Characteristics

HEIGHT

Wild Parsnip can grow to a height of 0.5 to 1.5 metres.

STEMS

Wild Parsnip has a single light green (sometimes purple tinged) deeply grooved, hollow stem (except at the nodes) and stands between 5 and 150 cm tall. It is smooth (with few hairs), and typically 2.5 to 5 cm in diameter.

LEAVES

The leaves of Wild Parsnip are alternate on the stem, pinnately compound, approximately 15 cm in length, with saw toothed edges. Leaves are further divided into leaflets that grow across from each other along the stem, with 2 to 5 pairs of opposite leaflets and one diamond-shaped terminal leaflet. The petiole (the stem of the leaf) on lower leaves is longer than that on leaves closer to the top of the stem.

ROOTS

Wild Parsnip has a thick funnel shaped taproot, which can grow to a depth of 1.5 metres. This root is where energy reserves are stored during its first year. It is thought to benefit the plant during times of drought, storing moisture and nutrients.

FLOWERS

Wild Parsnip has small yellow, 5-petalled flowers growing in clusters that in Canada bloom from June through to October. Petals are yellow, usually without bracts or bractlets (small leaves at the base of the flower), with small or non-existent sepals (small leaves that protect flowers before they open). Flowers are arranged in 15 to 25 rays, of unequal length, and grow in a flat umbrella-shaped umbel that is 5 to 15 cm across.

FRUIT

After flowering, Wild Parsnip plants produce a dry fruit or seed called a schizocarp. This fruit is about 6 mm long, oval, and once matured, splits into 2 sections called mericarps, which are flat, smooth, round and 5 to 7 mm long. Each mericarp contains a seed, which matures in mid-summer. Seeds usually remain attached to the dead stalks and seed dispersal can take place between August and November (with September being the most common time). Seeds can remain viable in soil for up to five years.



Photo by: David Featherstone



Photo by: Bob Bowles



Photo by: John Kemp



Photo by: David Featherstone and Parks Canada

BIOLOGY AND LIFE CYCLE

Wild Parsnip reproduces only via seed (sexual reproduction) and seeds are carried and spread to new areas by wind and water, and on mowing or other equipment. One plant produces, on average, 975 seeds with a median dispersal distance of 3 metres (lighter seeds are carried further than larger, heavier ones). Growth of the plant begins in the spring and lasts through early autumn. In its more southern range, the plant may keep some of its leaves all winter.

The plant takes two or more years to mature, and spends its first year (or more) as a basal rosette growing close to the ground. During this first year as a basal rosette, the plant stores its reserves in a large taproot. Once the plant matures, it flowers, and then dies.

HABITAT

Wild Parsnip is most often found in areas exposed to full sun, although it can grow in the semi-shade of forests and riverbanks. It is tolerant of a variety of soils, but cannot survive in flooded environments. Its deep taproot is thought to be of benefit during times of drought. In its native range Wild Parsnip grows best in rich, moist alkaline soils, while in Canada it appears to do well in a variety of soil conditions.

In Canada, Wild Parsnip is most often found in disturbed areas (i.e. railway embankments, roadsides, trails, shorelines, ditches, beaches, forest clearings and areas such as abandoned mine sites, quarries, and waste areas). Less common sites include cultivated fields, gardens, meadows, swampy lowlands and grassy areas.

Ontario populations are commonly found growing along fence rows, the edge of agricultural fields, watercourses and drainage areas. It often grows along with perennial grasses. Parsnip is still cultivated for human consumption.

It is harvested in its first year of growth, just after the large taproot has formed. Wild Parsnip plants may actually be recent escapees of cultivated crops.

There are no known cases of Wild Parsnip hybridizing with other species.

Poison Ivy

Poison Ivy is a low-growing form with shorter erect stem and a flower cluster to form the axil of one compound leaf. There is a cluster of dry white, berrylike fruits produced from the flower cluster. It is a perennial plant and spreads by seed and by woody rhizomes (underground stems) which produce dense patches.

It is distinguished by its low growth or its occasional climbing habit, its 3 leaflets in each compound leaf, its leaves which are deep green in summer, reddish in spring and fall, its clusters of whitish to greenish-yellow berries, and its short, erect, leafless stems which frequently retain a few berries all winter long. Poison-ivy is sometimes mistakenly called Poison-oak because some plants have very coarsely toothed or lobed leaflets. The true Poison-oak, *Rhus toxicodendron* L. occurs in the southern United States, but not in Canada.

Plant Characteristics

STEMS

Stems woody and of two kinds, the most frequent kind growing horizontally on or just below the ground surface with upright leafy stalks 10-80 cm (4-32 in.) high; the second kind is a climbing vine which develops aerial roots and may climb 6-10 m per node, compound, each compound leaf consisting of 3 leaflets at the tip of a long leafstalk (petiole); the middle leaflet has a longer stalk than the 2 side leaflets; overall leaflet shape and type of tothing highly variable between leaflets on the same stem, as well as among plants within a patch and between patches; leaflets ranging from narrow to broadly ovate with a smooth margin, to a few scattered, shallow, rounded teeth, to several, coarse, deep-pointed teeth which give the leaflet a lobed appearance; leaves purplish to reddish when unfolding in spring (May to early June), bright green and often shiny (with a varnished appearance) in summer and turning a vivid orange-red to wine-red in autumn in sunny areas, but often lacking the bright colour in shaded places; leaflet smooth and hairless on both surfaces except for small tufts of brownish hair on the underside along the mid-vein and in the angles formed by the mid-vein and some of the lower branching veins.

FLOWERS

Flowers small, white or greenish, with 5 sepals and 5 petals, in branching clusters from the leaf axils (angles between leafstalk and stem); flower clusters inconspicuous because they are often hidden below the dense leaf canopy and because many plants do not flower every year.

FRUIT

Each flower in the cluster followed by a whitish to dull greenish-yellow, dry, berry-like fruit about 5 mm (1/5 in.) in diameter with lengthwise ridges and somewhat resembling a peeled

orange. Flowers in June and July; berries produced by September but often remaining on the low leafless stems all winter.



BIOLOGY AND LIFE CYCLE

All parts of Poison-ivy, including the roots, contain a poisonous substance which causes an irritating inflammation of the skin of most people, the inflamed areas frequently developing blisters and accompanied by intense itchiness. The poisonous substance is an oily resin contained in the juice of the plant. Contact with any broken part of the plant, with leaves which have been chewed by insects, or with shoes, clothing, implements, or pets which have touched broken parts of the plant may cause a person with sensitive skin to react. Dry twigs in winter or dug-up roots in summer can often cause a reaction. Burning Poison-ivy leaves and stems releases the poison in the form of tiny droplets on particles of ash and dust in the smoke, and can cause a severe reaction on exposed skin and in the breathing passages if a sensitive person

breathes or passes through the smoke of such a fire. The author had a severe reaction on his arms and legs after trimming a specimen plant with hand clippers. Although the plant parts never touched his clothes, it seems that microscopic oil droplets may have squirted out while cutting the stems and vines and penetrated the cotton of his trouser legs and shirt sleeves. In cases of suspected contact with the plant, washing the skin and clothing with a strong soap may not prevent a reaction but it will help minimize reinfection to other parts of the body or to other individuals. If a reaction does develop, one should seek the advice of a physician for proper treatment. Poison-ivy is designated as a noxious weed by the Province of Ontario, and it is the duty of every person in possession of infested land to destroy noxious weeds thereon.

HABITAT

Poison-ivy occurs under forests, in edges of woodland, meadows, waste areas, fence lines, and roadsides throughout most of Ontario south of a line from North Bay to Kenora. The tall climbing vine form, however, is mainly confined to the counties bordering Lake Erie, Lake Ontario and the lower Ottawa Valley.

Giant Hogweed

Giant Hogweed (*Heracleum mantegazzianum*), also known as Giant Cow Parsnip is a perennial plant and a member of the carrot family. It is a garden ornamental from southwest Asia that is naturalizing in North America and becoming more common in southern and central Ontario. Giant Hogweed has the potential to spread readily and grows along roadsides, ditches and streams. It invades old fields and native habitats such as open woodlands.

There are a number of plants that look very similar to Giant Hogweed such as Cow Parsnip, Purplestem angelica, Woodland angelica, Valerian, Lovage, and Queen Anne's-Lace (also known as Wild carrot). However, these plants are not as large as a mature Giant Hogweed, which grows up to 5.5 metres tall under ideal conditions. The white flower clusters resemble those of Queen Anne's-Lace, but tend to be more widely spaced and can form a flower-head almost one metre wide.





Giant hogweed seedling.
Photo courtesy of Rachel Gagnon, Ontario Invasive Plant Council.



Giant hogweed stalk and flower clusters.
Photo courtesy of Karen Iimer.



Photo by: Joe Perreira

BIOLOGY AND LIFE CYCLE

Seeds may take several years to germinate and are viable in the soil for up to 15 years. During the first year, the plant produces a rosette of leaves up to one metre high. After 2 to 5 years the plant produces flowers. As it grows a large root, thick hollow stems and large lobed leaves are formed.

The stems of the plant are covered with reddish-purple flecks and stiff hairs filled with sap. Sap may also collect in the hollow stem bases. Giant Hogweed flowers once in its lifetime, unless the flower clusters are damaged before opening. Once the plant produces seeds it dies. Each plant can produce up to 120,000 winged seeds (typically 50,000).

Seeds dropped in streams can float for three days. They can move long distances via water in ditches and streams. Seeds can also be spread up to 10 metres by the wind.

There is evidence that Giant Hogweed can shade out native plants, although scientists have not done extensive research on its impact in Ontario or Canada. In the United Kingdom it grows in areas bordering lakes, streams, and wetlands and causes rocks, soil and other material on stream banks to fall into streams. This threatens salmon spawning sites. Similar impacts may occur in Ontario.





The clear watery sap of Giant Hogweed contains toxins that can cause severe dermatitis (inflammation of the skin). You can get severe burns if you get the sap on your skin and the skin is then exposed to sunlight. Symptoms occur within 48 hours and consist of painful blisters. Purplish scars may form that last for many years. Eye contact with the sap has been reported (in the media and by various web sites) to cause temporary or permanent blindness. However, evidence of permanent blindness linked to exposure to Giant Hogweed cannot be substantiated by any existing research. Coming in contact with Cow Parsnip and Wild Parsnip can cause similar reactions.

HABITAT

Giant Hogweed has a scattered distribution across southern and central Ontario, south of the line from Manitoulin Island to Ottawa.

LOOK-ALIKES

	Wild Parsnip (<i>Pastinaca sativa</i>)	Giant Hogweed (<i>Heracleum mantegazzianum</i>)	Cow Parsnip (<i>Heracleum maximum</i>)	Queen Anne's Lace (<i>Daucus carota</i>)	Angelica (<i>Angelica</i> spp.)
	 Photo courtesy of David McMurray.	 Photo courtesy of Ken Towle.	 Photo courtesy of Lynda Shores.	 Photo courtesy of Chris Evans, Illinois Wildlife Action Plan, Bugwood.org.	 Photo courtesy of Owen Williams.
Stem	<ul style="list-style-type: none"> • 0.5 to 1.5 m 	<ul style="list-style-type: none"> • 2.5 to 5 m 	<ul style="list-style-type: none"> • 1 to 2.5 m 	<ul style="list-style-type: none"> • 0.3 to 1.5 m 	<ul style="list-style-type: none"> • 1.2 to 2.1 m
Flowers	<ul style="list-style-type: none"> • Yellow flower clusters 10 to 20 cm across 	<ul style="list-style-type: none"> • Large, white umbrella-shaped flower clusters 30 to 90 cm across, made up of 50 to 150 small flower clusters 	<ul style="list-style-type: none"> • White umbrella-shaped flower cluster • 10 to 30 cm across, made up of 15 to 30 small clusters 	<ul style="list-style-type: none"> • White flower cluster 5 to 10 cm across • Pale pink before fully opened • Often single purple flower in centre of flower cluster 	<ul style="list-style-type: none"> • Greenish-white globe-like flower clusters 8 to 25 cm across
Stem	<ul style="list-style-type: none"> • Green, 2.5 to 5 cm thick • Smooth with few hairs 	<ul style="list-style-type: none"> • Hollow, 5 to 15 cm thick • Prominent purple blotches • Distinct, coarse, bristly hairs 	<ul style="list-style-type: none"> • Hollow, 5 cm thick at base • Green, few to no purple spots • Soft and fuzzy hairs 	<ul style="list-style-type: none"> • Green, 1 to 2.5 cm thick • Covered with fine bristly hairs 	<ul style="list-style-type: none"> • Purple or purple blotched • Smooth (no hairs)

	Wild Parsnip (<i>Pastinaca sativa</i>)	Giant Hogweed (<i>Heracleum mantegazzianum</i>)	Cow Parsnip (<i>Heracleum maximum</i>)	Queen Anne's Lace (<i>Daucus carota</i>)	Angelica (<i>Angelica</i> spp.)
	 Photo courtesy of David McMurray.	 Photo courtesy of Ken Towle.	 Photo courtesy of Lynda Shores.	 Photo courtesy of Chris Evans, Illinois Wildlife Action Plan, Bugwood.org.	 Photo courtesy of Owen Williams.
Lifecycle	<ul style="list-style-type: none"> • Biennial (lives for 2 years) or perennial (lives longer than 2 years) 	<ul style="list-style-type: none"> • Biennial/Perennial 	<ul style="list-style-type: none"> • Perennial 	<ul style="list-style-type: none"> • Biennial 	<ul style="list-style-type: none"> • Perennial
Origin	<ul style="list-style-type: none"> • Invasive 	<ul style="list-style-type: none"> • Invasive 	<ul style="list-style-type: none"> • Native 	<ul style="list-style-type: none"> • Invasive 	<ul style="list-style-type: none"> • Native

Other native and non-native species that share similar appearances include Water Parsnip (*Sium suave*), Spotted Water Hemlock (*Cicuta maculate*) and Poison Hemlock (*Conium maculatum*).

Source: Best Management Practices in Ontario

Appendix “B”

Noxious Plant Map

Technical Guidelines

(Best Management Practices & Resource Material)

for the

Integrated Pest Management Plan

COUNTY OF RENFREW

Noxious / Hazards / Invasive Plant Mapping - 2016

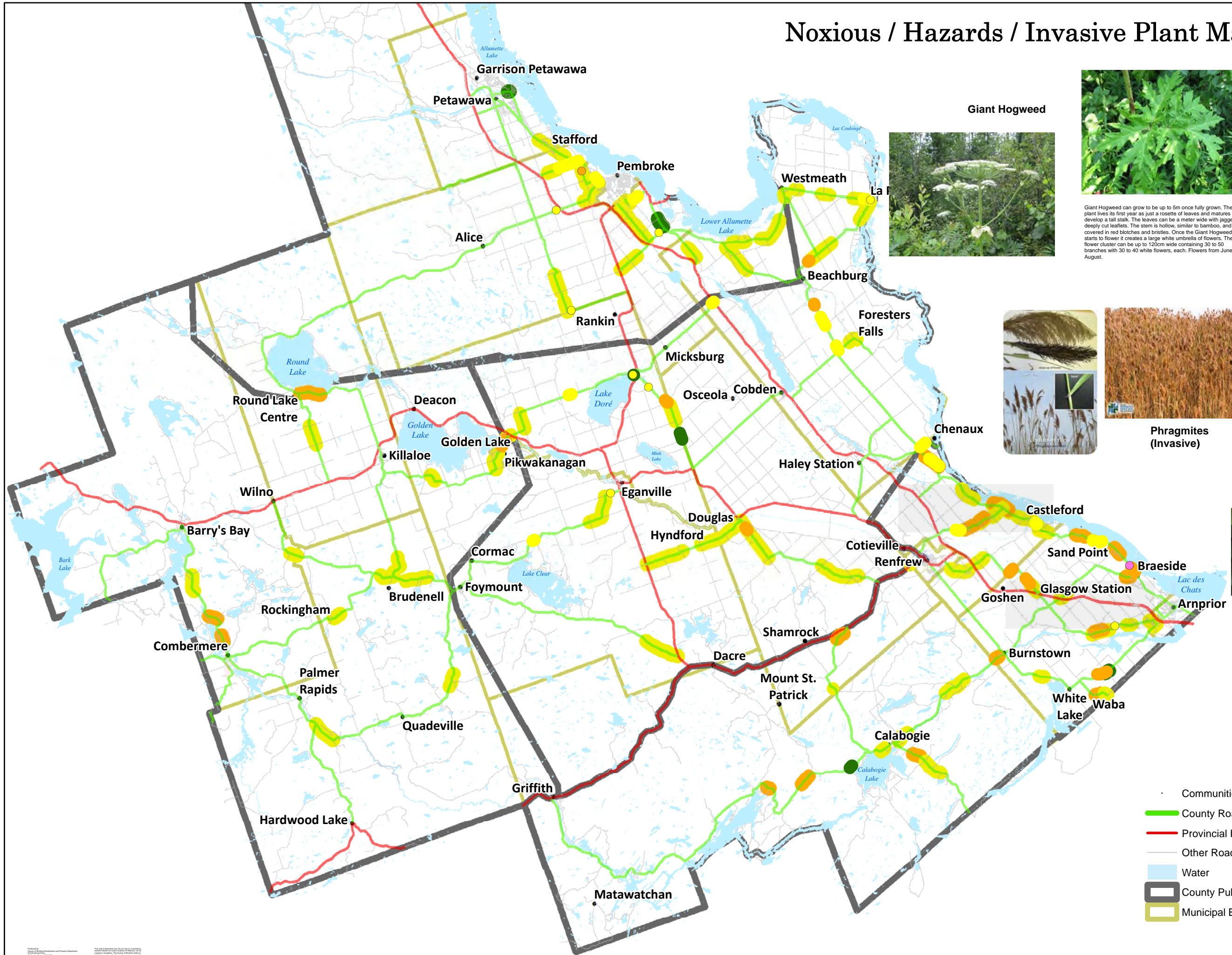

Giant Hogweed



Wild Parsnip



Giant Hogweed can grow to be up to 5m once fully grown. The plant lives its first year as just a rosette of leaves and matures to develop a tall stalk. The leaves can be a meter wide with jagged deeply cut leaflets. The stem is hollow, similar to bamboo, and is covered in red blotches and bristles. Once the Giant Hogweed starts to flower it creates a large white umbrella of flowers. The flower cluster can be up to 120cm wide containing 30 to 50 branches with 30 to 40 white flowers, each. Flowers from June to August.

The leaves of Wild Parsnip are heavily toothed and can have a distinct mitten shape. The plant has 5 to 7 leaflets per leaf that form a diamond shape leaflet structure. The plant produces clusters of individual small bright yellow flowers, 10 to 20cm in diameter. Wild parsnip can grow to a height of 50 to 150cm.



Phragmites (Invasive)



Poison Ivy



The leaves hang from the stem in groups of three. The lobes on the bottom edge of the lower leaves are more distinct than the top edges (1), the middle stem is longer than the other two (2), and the middle leaf is only lobed on the top half of the leaf (3). Some leaves are also completely smooth.

- Communities
- County Road
- Provincial Highway
- Other Roads
- Water
- County Public Works Patrol Areas
- Municipal Boundary
- Giant Hogweed
- Phragmites
- Poison Ivy
- Wild Parsnip

Appendix “C”

Decision Matrices

Technical Guidelines

(Best Management Practices & Resource Material)

for the

Integrated Pest Management Plan

COUNTY OF RENFREW

Site Prioritization Flow Chart

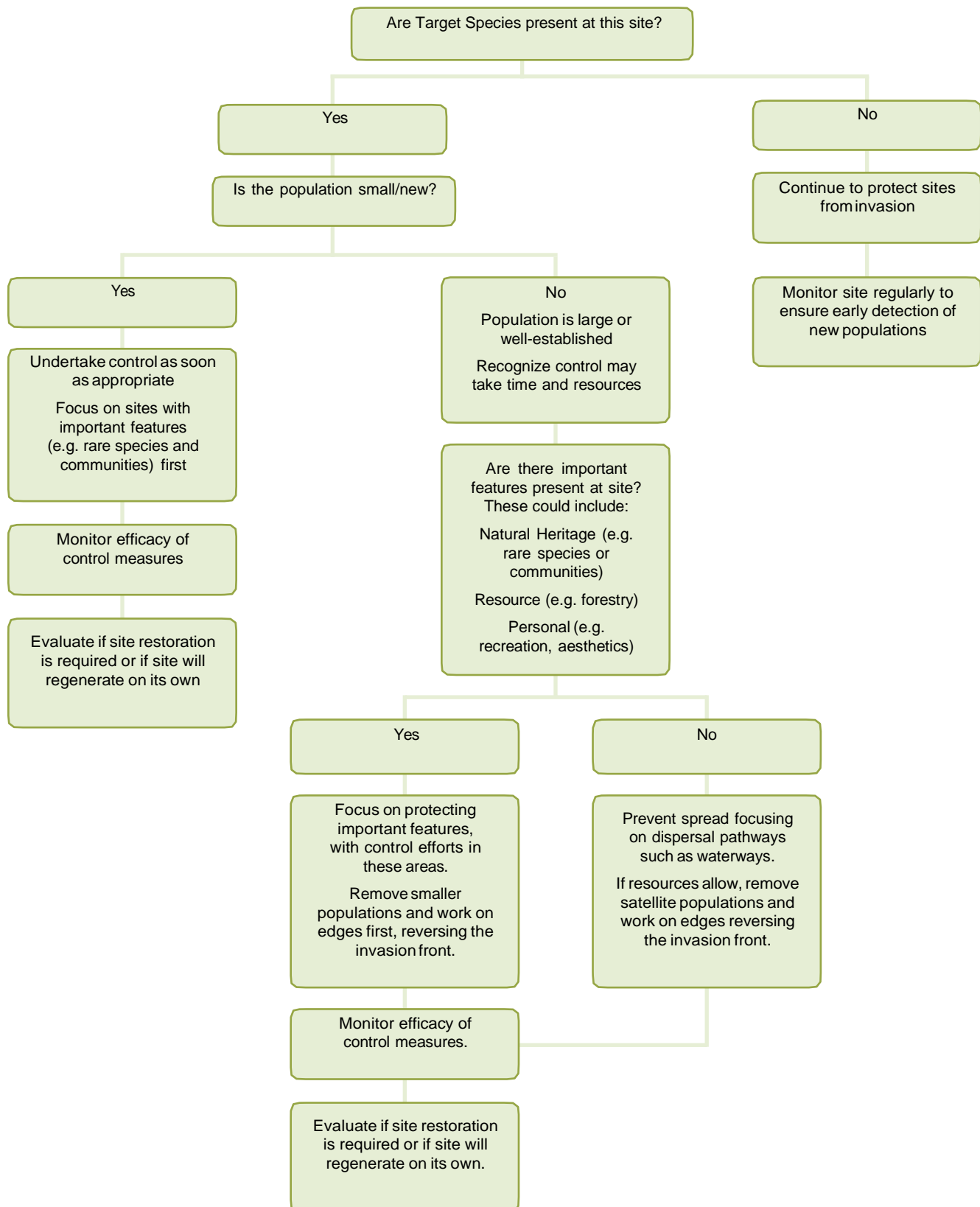

Choosing the Best Control Method

		Isolated Plants	Small (.1-.5ha)	Medium (.5-2ha)	Large (more than 2 ha)
Density of Infested Area	Low Density (1-50 plants or less than 10% cover)	Pulling	Pulling, mowing, tarping, burning	Pulling, mowing, tarping, tillage, burning	Mowing, tarping, tillage, burning
	Medium Density (50-1000 plants or between 10% and 30% cover)		Mowing, tarping, burning, chemical	Mowing, tarping, tillage, burning, chemical	Mowing, tarping, tillage, burning, chemical
	High Density (more than 1000 plants or 30 – 100% cover)		Mowing, tarping burning, chemical, biological	Mowing, tarping, tillage, burning, chemical, biological	Mowing, tarping, tillage, burning, chemical, biological

Control Measures Summary

Method	Population Characteristics	Purpose of Control	Notes
Pulling	<ul style="list-style-type: none"> • Small to medium 	<ul style="list-style-type: none"> • Removal of all plants 	<ul style="list-style-type: none"> • Roots must be removed
Mowing/ Cutting	<ul style="list-style-type: none"> • Small to large 	<ul style="list-style-type: none"> • Reduce seed production and plant density 	<ul style="list-style-type: none"> • Timing is critical
Tarping	<ul style="list-style-type: none"> • Any size of population, dependent on resources 	<ul style="list-style-type: none"> • Reduce growth and seed production 	<ul style="list-style-type: none"> • Use in conjunction with other control methods
Tillage	<ul style="list-style-type: none"> • Medium to large 	<ul style="list-style-type: none"> • Reduce growth and seed production 	<ul style="list-style-type: none"> • For use on agricultural land
Burning	<ul style="list-style-type: none"> • Any size of population 	<ul style="list-style-type: none"> • Removal of top growth, depletion of root reserves 	<ul style="list-style-type: none"> • Burning can encourage the growth of native species that may outcompete Wild Parsnip, use in conjunction with other control methods and caution must be taken during a controlled burn
Chemical	<ul style="list-style-type: none"> • Large populations 	<ul style="list-style-type: none"> • Herbicide application; eradication or control to manageable levels 	<ul style="list-style-type: none"> • Multiple applications may be necessary
Biological	<ul style="list-style-type: none"> • Large populations 	<ul style="list-style-type: none"> • Once a population is past manageable or treatable levels, often the only viable control option is biological control (introduction of a predator, disease or pathogen to reduce populations) 	<ul style="list-style-type: none"> • No biological control is currently available

Appendix “D”

Health and Safety

Technical Guidelines

(Best Management Practices & Resource Material)

for the

Integrated Pest Management Plan

COUNTY OF RENFREW

Health and Safety

Working with Toxic Plants

When controlling hazardous/toxic vegetation, protective clothing, including waterproof gloves, long sleeve shirts and pants, and eye protection are necessary. Ideally, wear disposable “spray suit” coveralls over normal clothing (spray suits are commercial grade waterproof coveralls). Tape coveralls at the wrist to minimize potential skin exposure to the sap.

Remove protective clothing carefully to reduce the risk of skin coming into contact with sap that may be on your clothing.

1. Wash rubber gloves first with soap and water prior to removing other clothing.
2. Remove disposable spray suit or other protective clothing.
3. Wash rubber gloves again before removing them.
4. Lastly, remove protective eye wear.
5. Place non-disposable clothing in the laundry and wash yourself immediately with soap and water.

Exposure to Toxic and Hazardous Plant Species

1. If skin comes into contact with sap from a toxic species of plant, wash it thoroughly with soap and cold water.
2. Avoid further exposure of the affected skin to UV/sunlight as a significant quantity of toxic plants toxins are photo sensitive.
3. If a rash, blisters, etc. occurs, seek medical attention.
4. If there is a chance your eyes were exposed to direct contact with the sap, immediately flush the eye with water and seek immediate medical attention.
5. If the fumes from the burning of toxic plants is accidentally inhaled, seek immediate medical attention.
6. If the toxic plants are accidentally ingested, seek immediate medical attention.

Caution

The hazardous chemicals in toxic plant species can remain active for several years. Handling dead leaves or vines may cause a reaction therefore take caution when working in areas identified or previously identified as containing hazardous plants (mapping) and areas with characteristics that may support these plants, as it is possible that new areas may be infested.

Appendix “E”

Distribution

Technical Guidelines

(Best Management Practices & Resource Material)

for the

Integrated Pest Management Plan

COUNTY OF RENFREW

Distribution

Wild Parsnip is native to much of temperate Europe, Eastern Europe and western Central Asia (growing in Turkey, Iran, the Caucasus region, and the Western Himalayans).

During the last 15 to 20 years, Wild Parsnip has become increasingly common around eastern Ontario, with large populations east of Belleville and in western Quebec. It is now spreading west across the province. In the United States it's found in most states, with the exception of Alabama, Hawaii, Georgia and Florida.

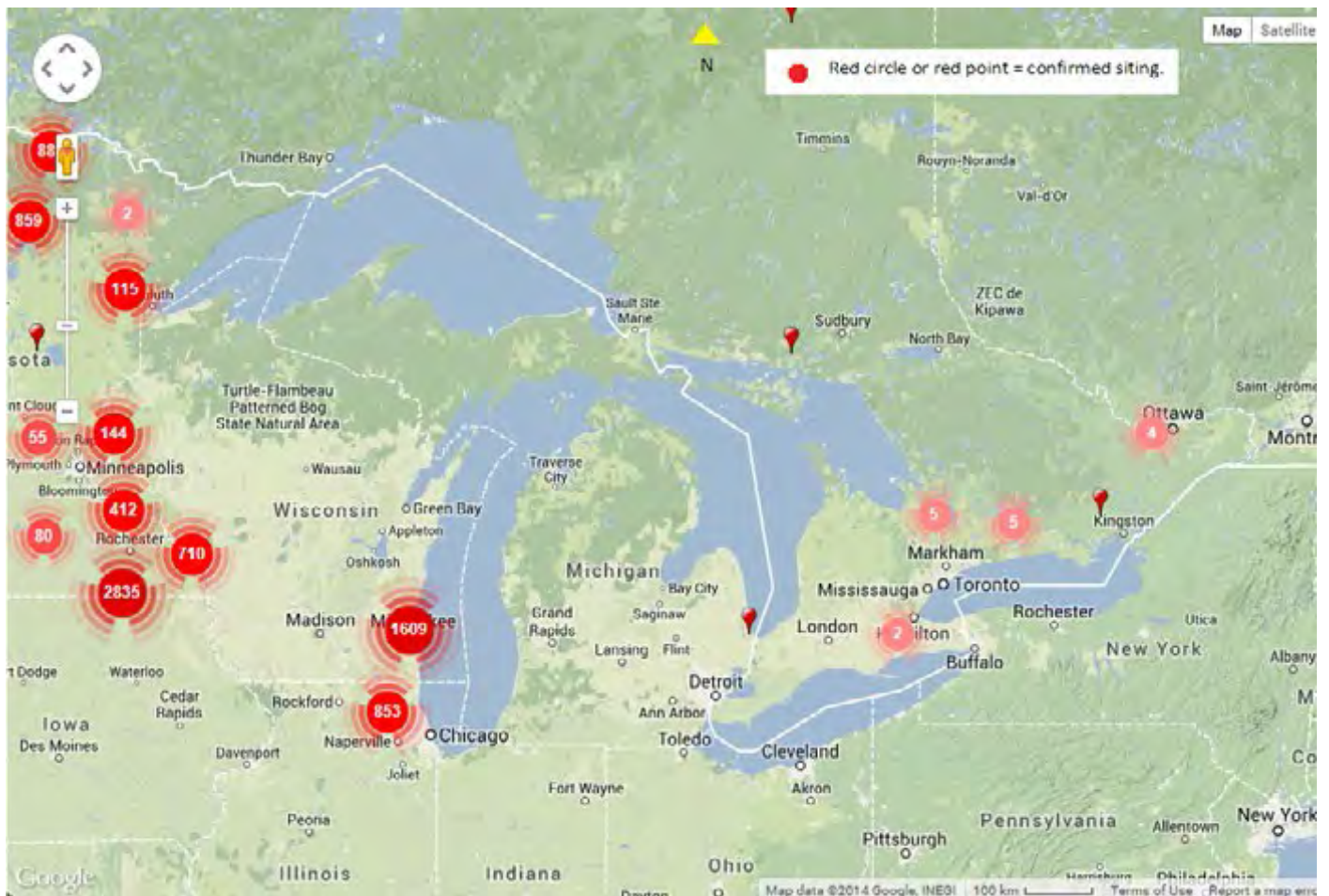

Wild Parsnip Distribution Map courtesy of EDDMapS (www.eddmaps.org/ontario). The map point data is based on records contained in the Invasive Species Database, compiled from various sources as of February 13, 2014. This map is illustrative only. Do not rely on this map as a definitive distribution as it is subject to change based on additional confirmed invasive species sites. This map may contain cartographic errors or omissions.

GIANT HOGWEED

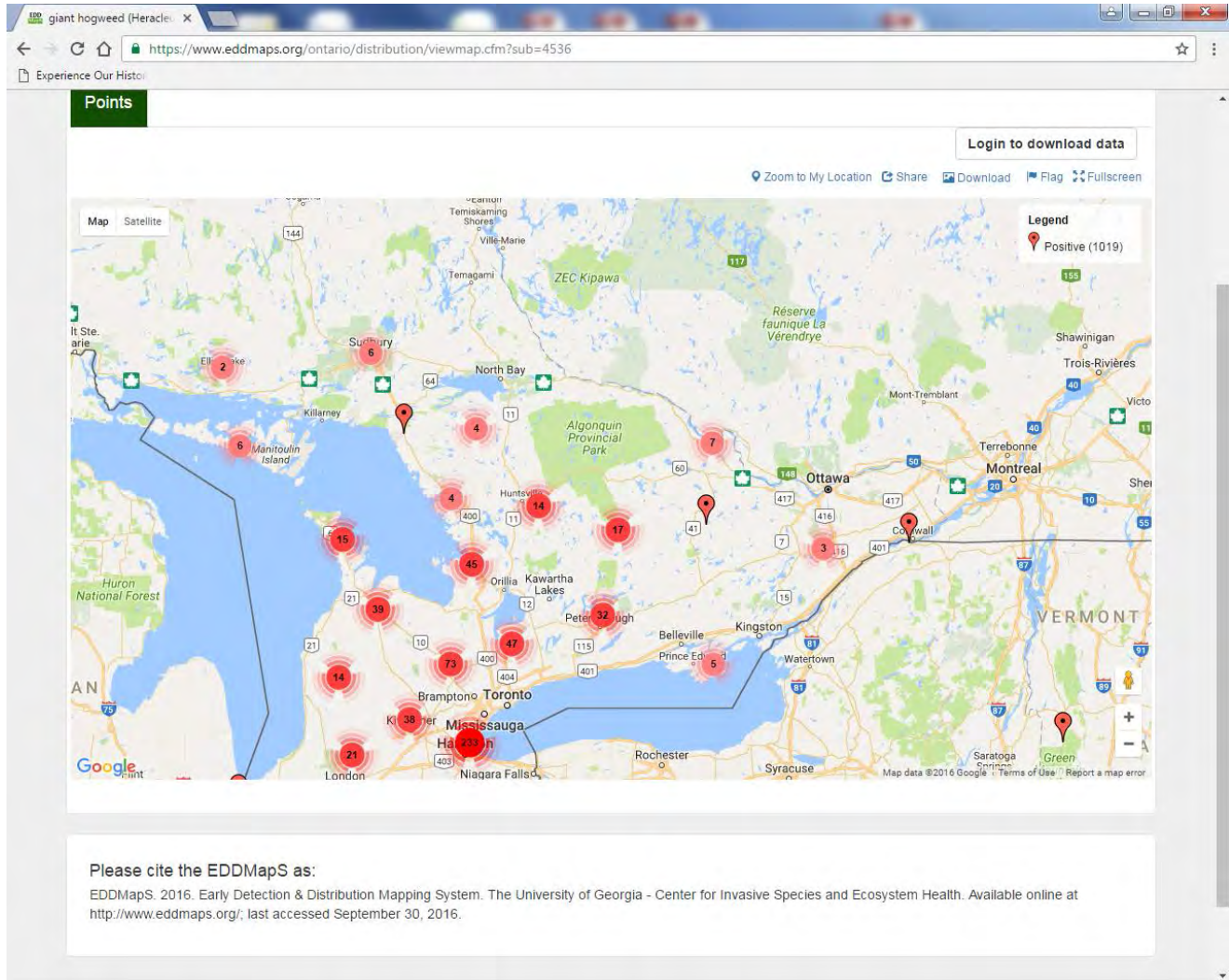

Appendix “F”

Clean Equipment Protocol

Technical Guidelines

(Best Management Practices & Resource Material)

for the

Integrated Pest Management Plan

COUNTY OF RENFREW

Clean Equipment Protocol for Industry

Inspecting and cleaning equipment for the purposes of invasive species prevention



Invasive
Species
Centre

Catalyst for research and response



Ontario



ONTARIO
INVASIVE PLANT
COUNCIL

Publication Information

Halloran, Joe, Anderson, Hayley and Tassie, Danielle. 2013. Clean Equipment Protocol for Industry. Peterborough Stewardship Council and Ontario Invasive Plant Council. Peterborough, ON.

Printed April 2013

Updated May 2016.

Peterborough, Ontario

ISBN: (to be confirmed)

This document was prepared for the Canada-Ontario Invasive Species Centre and the Ontario Ministry of Natural Resources by the Peterborough Stewardship Council and the Ontario Invasive Plant Council.

Inquiries regarding this document can be directed to the Ontario Invasive Plant Council

PO Box 2800, 4601 Guthrie Drive

Peterborough, ON

K9J 8L5

Phone: (705) 748-6324

Email: info@ontarioinvasiveplants.ca

For more information on invasive plants in Ontario, visit www.ontario.ca/invasivespecies, www.ontarioinvasiveplants.ca, www.invadingspecies.com, or www.invasivespeciescentre.ca.

Table Of Contents

Introduction	1
Why Cleaning Vehicles and Equipment is Important	3
Impacts of Invasive Species on Industry	4
Construction	4
Forestry/Agriculture	4
Land Management (Trail Use/Maintenance).....	4
Roadsides/Utilities	4
Steps to Prevent the Unintentional Introduction of Invasive Species from Equipment	5
When to Inspect	5
How to Inspect	5
When to Clean.....	6
Where to Clean	6
How to Clean Inside	6
How to Clean Outside	6
Final Inspection Checklist	7
Equipment Required	7
Inspection and Cleaning Diagrams and Checklists	8
2WD and 4WD Vehicles.....	8
Excavator	9
Backhoe.....	10
Bulldozer	11
Contacts and Resources	12
Appendix A: Identification of Invasive Plants Found in Ontario	13

Introduction

Why Invasive Plants are a Problem

Invasive alien species are “a growing environmental and economic threat to Ontario. Alien species are plants, animals and microorganisms that have been accidentally or deliberately introduced into areas beyond their normal range. Invasive species are defined as harmful alien species whose introduction or spread threatens the environment, the economy, or society, including human health (Government of Canada 2004).” (Ontario Invasive Species Strategic Plan, 2012). The great majority of plant invasions occur in habitats that have been disturbed either naturally or by humans (Rejmanek 1989; Hobbs and Huenneke 1992; Hobbs 2000).

The ecological effects of invasive species are often irreversible and, once established, they are extremely difficult and costly to control or eradicate. According to Pimental et al. (1999), invasive species in the U.S. cause economic and environmental damages totalling over \$138 billion per year, with agricultural weed control and crop losses totalling approximately \$34 billion per year. Exact figures for the total economic and environmental damages are not available for Canada. In Ontario however, the costs of dealing with just one invasive species is astonishing; Zebra Mussels cost Ontario power producers who draw water from the lake \$6.4 million per year in increased control/operating costs and about \$1 million per year in research costs (Colautti et al. 2006).

Invasive species can spread to new areas when contaminated mud, gravel, water, soil and plant material are unknowingly moved by equipment used on different sites. This method of spread is called an unintentional introduction, and is one of the four major pathways for invasive species introduction into a new area of Ontario (Ontario Invasive Species Strategic Plan, 2012).



Buckthorn removal, Lynde Shores Conservation Area.

Photo by: Central Lake Ontario Conservation Authority

Invasive plant seed and other propagules (plant material, i.e. rhizomes) have the ability to travel sight unseen in mud attached to or lodged in various parts and spaces between parts of vehicles, machinery and other mechanical equipment. A recent study at Montana State University found that most seeds (99% on paved roads and 96% on unpaved roads) stayed attached to the vehicle after traveling 160 miles (257 km) under dry conditions.

Invasive plant species are commonly transported on or in vehicles and construction equipment when they are moved to new locations. Those vehicles include four-wheel drives, excavators, tractors, loaders, water trucks and all-terrain vehicles. Failure to properly clean vehicles and machinery of soils, mud, and contaminated water that may contain invasive species seed and propagules can result in permanent, irreversible environmental impacts. These impacts can mean substantial cost to the landowner, land manager and/or the user. Businesses may also face liability issues for activities and operations that result in the introduction of invasive species.

Some of the invasive species in Ontario which have been known to spread through equipment transfer include:

- **Common Buckthorn** (*Rhamnus cathartica*)
- **Dog-strangling Vine** (*Cynanchum rossicum*)
- **Garlic Mustard** (*Alliaria petiolata*)
- **Giant Hogweed** (*Heracleum mantegazzianum*)
- **Glossy Buckthorn** (*Frangula alnus*)
- **Japanese Knotweed** (*Polygonum cuspidatum*)
- **Miscanthus or Chinese Silver Grass** (*Miscanthus sinensis*)
- **Invasive Phragmites or Common Reed** (*Phragmites australis subsp. australis*)
- **Reed Canary Grass** (*Phalaris arundinacea*)
- **Wild Parsnip** (*Pastinaca sativa*)
- **Wild Chervil** (*Anthriscus sylvestri*)



Dog-strangling Vine
(*Cynanchum rossicum*)
Photo by: Hayley Anderson



Garlic Mustard
(*Alliaria petiolata*)
Photo by: Ken Towle



Invasive Phragmites
(*Phragmites australis subsp. australis*)
Photo by: Michael Irvine

These plants impact biodiversity by out-competing native species for space, sunlight, and nutrients. They can also have impacts on road and driver safety by physically blocking intersection sightlines, and in the case of invasive *Phragmites* and *Miscanthus*, may fuel intense grass fires if ignited, which can damage utility stations and hydro lines.

The harmful effects of invasive species include:

- Physical and structural damage to infrastructure
- Human health hazards (i.e. giant hogweed and wild parsnip exposure)
- Delays and increased cost in construction activities
- Environmental damage (i.e. erosion)
- Aesthetic degradation
- Loss of biodiversity
- Reduced property values
- Loss of productivity in woodlots and agriculture

Why Cleaning Vehicles and Equipment is Important

Passenger and recreational vehicles as well as heavy machinery are major vectors for spreading terrestrial invasive species into new areas.

Preventing the spread of invasive species has proven to be considerably more cost effective than controlling established populations. The spread of invasive species through unintentional introduction can be minimized significantly by the diligent cleaning of vehicles and equipment when leaving one site and moving to the next. In the case of large properties, cleaning before moving to a new site is recommended, even if it is within the same property.

This guide has been developed for the construction, agriculture, forestry, and other land management industries, to provide equipment operators and practitioners with tools and techniques to identify and prevent the unintentional introduction of invasive species. It establishes a standard for cleaning vehicles and equipment and provides a guide where current codes of practice, industry standards or other environmental management plans are not already in place.

Passenger and recreational vehicles include:

- 2WD and 4WD cars
- 2WD and 4WD trucks
- All Terrain Vehicles (ATV's)
- Motorbikes
- Snowmobiles

Heavy machinery includes:

- Trucks
- Tractors
- Mowers
- Slashers
- Trailers
- Backhoes
- Graders
- Dozers
- Excavators
- Skidders
- Loaders
- Water Tankers and Trucks



Dog-strangling Vine plants attached to ATV.

Photo by: Francine Macdonald



Plant material attached to bobcat.

Photo by: TH9 Outdoor Services

Impacts of Invasive Species on Industry

Construction

In the UK, Japanese Knotweed (*Polygonum cuspidatum* or *Fallopia japonica*) is classified as a hazardous material. When construction occurs in established Japanese Knotweed stands workers sift the soil to remove root fragments and institute treatment plans to ensure that the Knotweed does not re-sprout, as it can damage housing foundations by growing through concrete and asphalt. The contractors must also thoroughly clean their equipment, and dispose of the contaminated soil at biohazard waste sites. While we do not have these requirements in Ontario, Japanese Knotweed is present here.

Invasive plant species can also increase site preparation and weed control costs, and reduce property values. For example, in Vermont the presence of the aquatic invasive plant Eurasian Watermilfoil (*Myriophyllum spicatum*) depressed shoreline residence property value by as much as 16.4% (Zhang and Boyle, 2010).

Forestry/Agriculture

Invasive plant species which become established in forests will out-compete native species and prevent forest re-generation after logging or natural disturbance. Dog-strangling Vine (*Cynanchum rossicum*) is of particular concern in conifer plantations. This species thrives in the filtered light and open soils of mature plantations, and suppresses seedling establishment of native hardwoods. If its invasion continues, very few juvenile trees will survive to fill the shrinking canopy of over-mature pines. Reforestation sites are also susceptible; the thick mats of vegetation and aggressive competition from Dog-strangling Vine decrease available planting space and increase costs as more mature vegetation needs to be planted in order to ensure the new vegetation can outcompete the invasive plant. As a result, expensive control programs are often required.

Land Management (Trail Use/Maintenance)

Recreational trail use and the maintenance of trails can facilitate the transport of invasive plant material and seeds, and create open and disturbed sites that are prime locations for the establishment of invasive species. Studies have proven that trails act as corridors which assist in the spread of invasive plant species. Humans, their pets, and vehicles such as ATV's can be vectors of invasion along trails because seeds and plant pieces can be carried on equipment and clothing. In addition, frequent trampling along trails alters soil properties, limits the growth of some native species, and creates conditions that may favour the growth of non-native species (Kuss et al. 1985; Marion et al. 1985; Yorks et al. 1997).

Roadsides/Utilities

Invasive species can increase the cost of roadside and utility maintenance by requiring additional maintenance and control efforts. The presence of invasive species can also provide a safety hazard. In the case of Phragmites and Miscanthus (invasive grass species), along with interrupting sight lines, the dead stalks which remain standing each autumn also provide combustible material. Fires in these stands burn intensely, and can damage utilities and hydro lines. Phragmites along roadsides is generally assumed to be spread through the transport and burial of rhizome fragments through ditching, ploughing, and other human activities that transport rhizomes on machinery. Studies have shown that vehicles and road-fill operations can transport invasive plant seeds into uninfested areas, and road construction and maintenance operations provide optimal disturbed sites for seed germination and seedling establishment (Schmidt 1989; Lonsdale & Lane 1994; Greenberg et al. 1997; Trombulak & Frissell 2000).

Steps to Prevent the Unintentional Introduction of Invasive Species from Equipment

Inspection and cleaning of all machinery and equipment should be performed in accordance with the procedures, checklists and diagrams provided in this protocol.

When visiting more than one site, always schedule work in the sites that are the least disturbed and free of known invasive species first, and visit sites with known invasive species infestations last. This will greatly reduce the risk of transferring plants to new locations.

When to Inspect

Inspection should be done before:

- Moving vehicles out of a local area of operation
- Moving machinery between properties or sites within the same property where invasive species may be present in one area, and not in another
- Using machinery along roadsides, in ditches, and along watercourses
- Vehicles using unformed dirt roads, trails or off road conditions
- Using machinery to transport soil and quarry materials
- Visiting remote areas where access by vehicles is limited

Inspection should be done after:

- Operating in areas known to have terrestrial invasive plants or are in high risk areas (i.e. recently disturbed areas near known invaded areas)
- Transporting material (i.e. soil) that is known to contain, or has the potential to contain, invasive species
- Operating in an area or transporting material that you are uncertain contain invasive species
- In the event of rain. If mud contains seeds, they can travel indefinitely until it rains or the road surface is wet, allowing for long distance transport. This may result in transporting seeds to areas where those species did not previously exist

How to Inspect

- Inspect the vehicle thoroughly inside and out for where dirt, plant material and seeds may be lodged or adhering to interior and exterior surfaces.
- Remove any guards, covers or plates that are easy to remove.
- Attention should be paid to the underside of the vehicle, radiators, spare tires, foot wells and bumper bars.

If clods of dirt, seed or other plant material are found, removal should take place immediately, using the techniques outlined below.

When to Clean

Vehicles and heavy equipment that stay on formed and sealed roads have a low risk of spreading invasive species. Cleaning is only required when inspection identifies visible dirt clods and plant material or when moving from one area to another.

Depending on the invasive species present, vehicles may need to be cleaned even when deep snow is present. Invasive *Phragmites*, for example, can still be spread, even in packed snow because the seed heads are usually above the surface of the snow. Other plants, such as dog-strangling vine, will be contained beneath deep snow.

**Regular inspection of vehicles and machinery will identify if any soil or plant material has been collected on or in vehicles and machinery.*

Where to Clean

Clean the vehicle/equipment in an area where contamination and seed spread is not possible (or limited). The site should be:

- Ideally, mud free, gravel covered or a hard surface. If this option is not available, choose a well maintained (i.e. regularly mowed) grassy area.
- Gently sloping to assist in draining water and material away from the vehicle or equipment. Care should be taken to ensure that localized erosion will not be created, and that water runs back into the area where contamination occurred.
- At least 30m away from any watercourse, water body and natural vegetation.
- Large enough to allow for adequate movement of larger vehicles and equipment.

**Safely locate the vehicle and equipment away from any hazards. If mechanized, ensure engine is off and the vehicle or equipment is immobilized.*

How to Clean Inside

Clean the interior of the vehicle by sweeping, vacuuming or using a compressed air device. Particular attention should be paid to the floor, foot wells, pedals, seats, and under the seats.

How to Clean Outside

Knock off all large clods of dirt. Use a pry bar or other device if necessary.

Identify areas that may require cleaning with compressed air rather than water such as radiators and grills. Clean these areas first prior to using water.

Clean the vehicle with a high pressure hose in combination with a stiff brush and/or pry bar to further assist the removal of dirt clods.

Start cleaning from the top of the vehicle and work down to the bottom.

Emphasis should be placed on the undersides, wheels, wheel arches, guards, chassis, engine bays, radiator, grills, and other attachments.

When the cleaning is finished avoid driving through the waste water when removing the vehicle or equipment from the cleaning site.

For equipment such as water trucks that may be exposed to aquatic invasive species, trucks should be disinfected with bleach solution before conducting work in a new area. For further information please refer to the Invading Species Awareness Program's Technical Guidelines listed under Contacts and Resources.



Hosing down a vehicle in Queensland, Australia

Photo by: TH9 Outdoor Services

Final Inspection Checklist

Conduct a final inspection to ensure the following general clean standard has been achieved:

- No clods of dirt should be visible after wash down.
- Radiators, grills, and the interiors of vehicles should be free of accumulations of seed, soil, mud and plant material parts including seeds, roots, flowers, fruit, and or stems.

Diagrams have been provided to assist in quickly identifying key areas to inspect and clean on a variety of vehicles associated with the targeted industries. These can be used in combination with vehicle checklists to ensure all areas of the vehicles have been inspected and cleaned.

Equipment Required

- A pump and high pressure hose OR high pressure water unit
- Minimum water pressure for vehicle cleaning should be at least 90 pounds per square inch. Water can be supplied as high volume/low pressure or low volume/high pressure (NOAA Fisheries Service).
- Air compressor and blower OR vacuum
- Shovel
- Pry bar
- Stiff brush or broom



Cleaning station at construction site.

Photo by: Mark Heaton, OMNR

Inspection and Cleaning Diagrams and Checklists

2WD and 4WD Vehicles

4WD VEHICLE WITH KEY SPOTS TO CHECK AND CLEAN

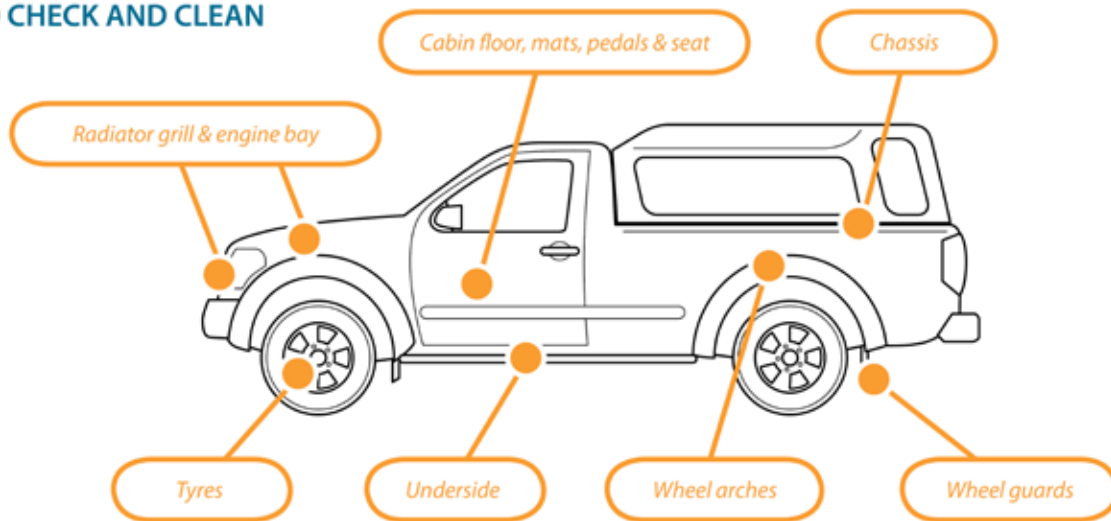

		✓
Cabin	Floor, mats, pedals, seats	
Engine	Radiators, engine bay, grill	
Body	Underside, chassis, crevices, ledges, bumper bars	
Wheels	All wheels (including spare), wheel arches, guards	
Tray	Floor, canopy (if included)	

Excavator

EXCAVATOR WITH KEY SPOTS TO CHECK AND CLEAN

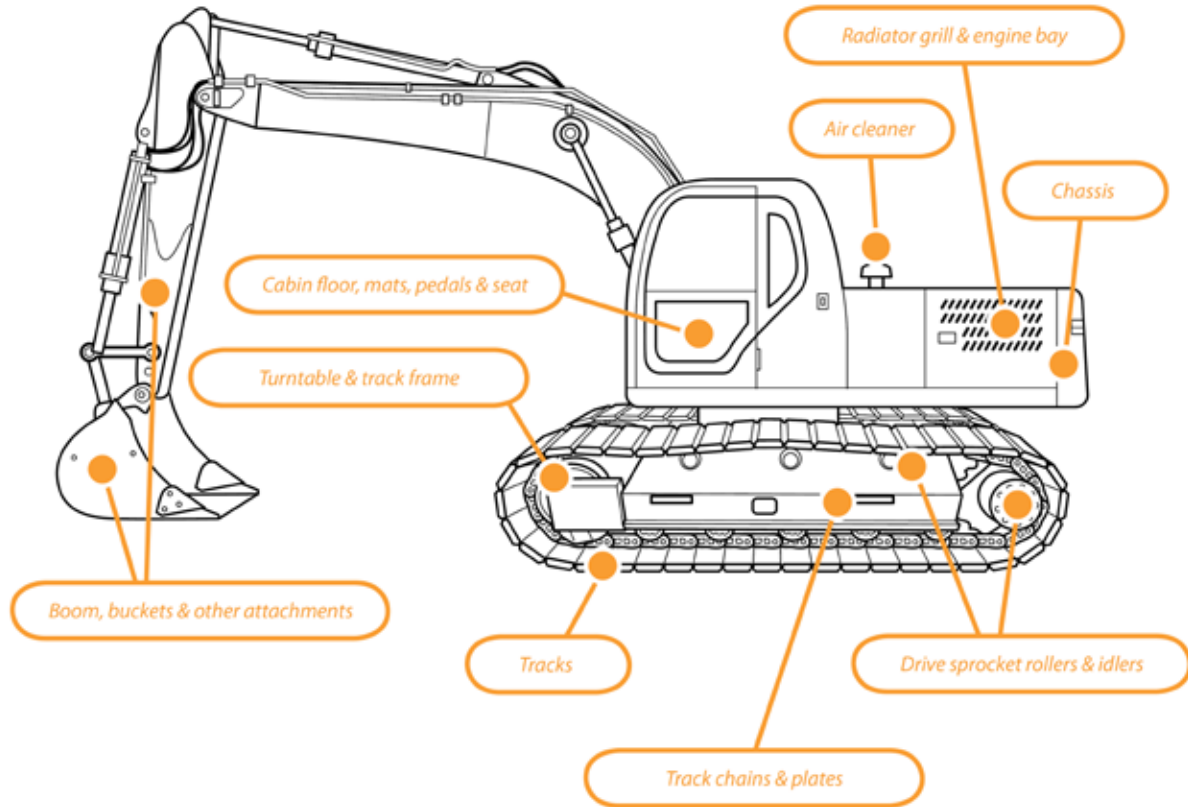

		✓
Cabin	Floor, mats, pedals, seats	
Engine	Radiators, engine bay, grill, air cleaner	
Tracks	Tracks, track frame, drive sprocket rollers, idlers	
Body Plates	Plates of cabin	
Body	Ledges, channels	
Bucket		
Booms		
Turret Pivot		

Backhoe

BACKHOE WITH KEY SPOTS TO CHECK AND CLEAN

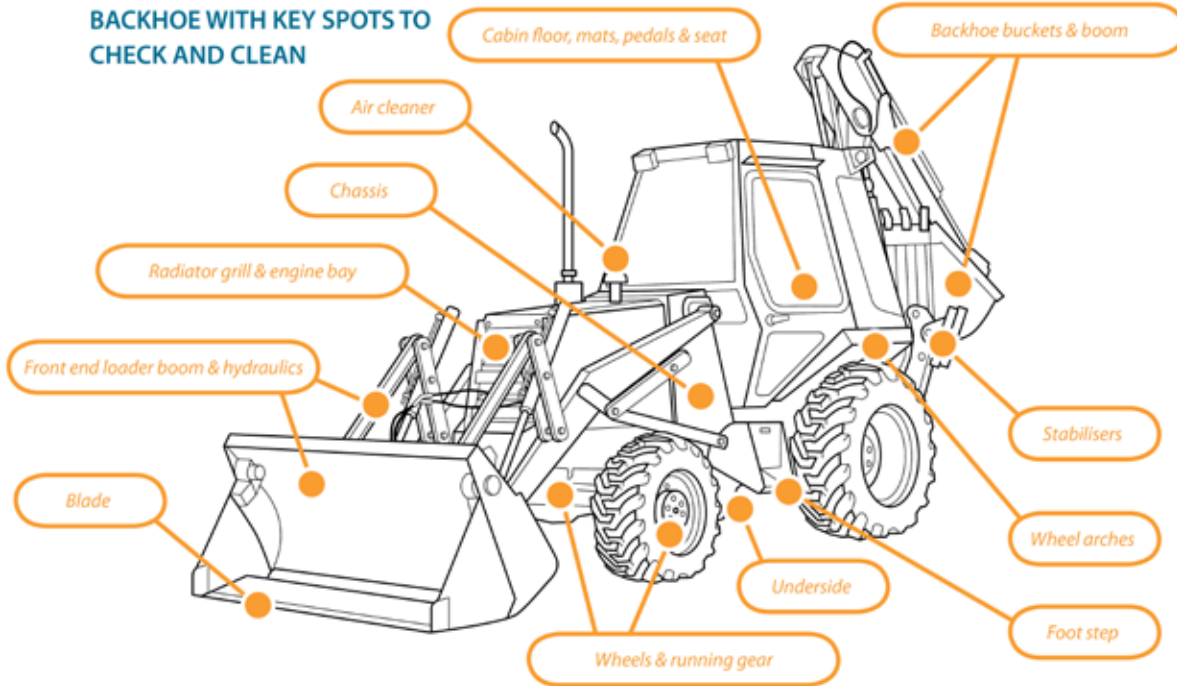

		✓
Cabin	Floor, mats, pedals, seats, foot step	
Engine	Radiators, engine bay, grill, air cleaner	
Wheels	All wheels (including spare), wheel arches, guards	
Front end loader	Blade, hydraulics, booms	
Backhoe	Buckets, boom, hydraulics, stabilisers	

Bulldozer

BULLDOZER WITH KEY SPOTS TO CHECK AND CLEAN

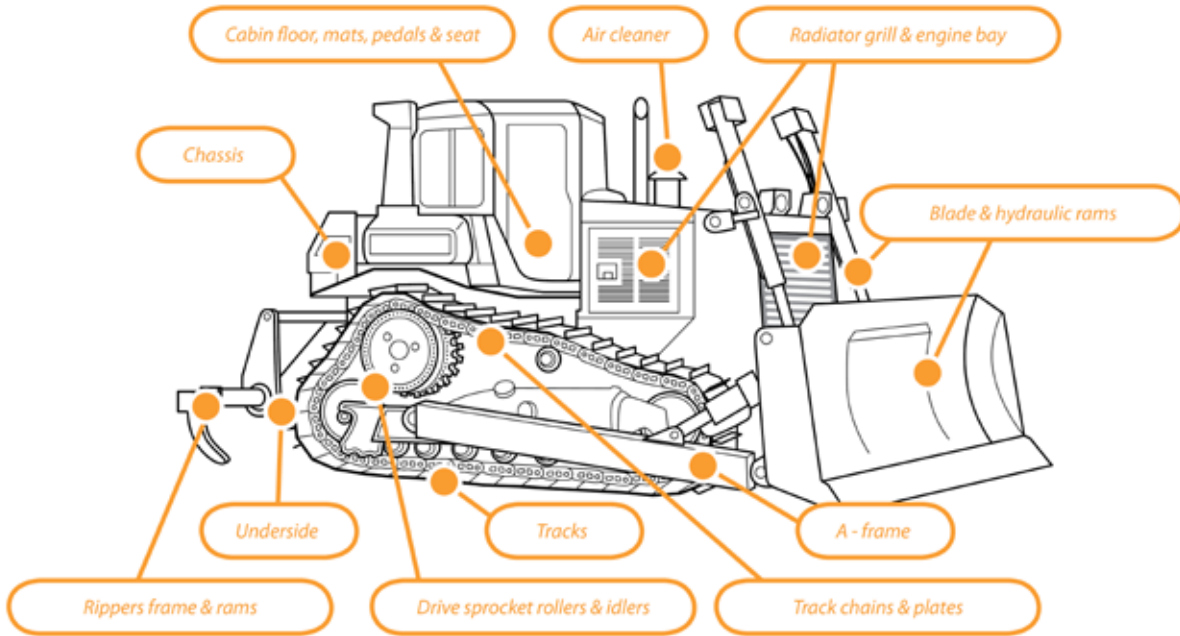

		✓
Cabin	Floor, mats, pedals, seats	
Engine	Radiators, engine bay, grill, air cleaner	
Tracks	Tracks, track frame, drive sprocket rollers, idlers	
Body Plates	Belly plates, rear plates	
Body	Ledges, channels	
Blade	Pivot points, hydraulic rams, a-frame	
Ripper	Ripper frame, ripper points	

Contacts and Resources

Ontario Invasive Species Strategic Plan 2012. Government of Ontario. Online, accessed May 8, 2012.

http://www.mnr.gov.on.ca/stdprodconsume/groups/lr/@mnr/@biodiversity/documents/document/stdprod_097634.pdf

Invasive Species Management for Infrastructure Managers and the Construction Industry 2008. Wade, M. Booy, O. and White, V. Online, accessed April 27, 2012.

http://www.ciria.org/service/Web_Site/AM/ContentManagerNet/ContentDisplay.aspx?Section=Web_Site&ContentID=9001

T.I.P.S (Targeted Invasive Plant Solutions) Highway Operations. British Columbia Invasive Species Council. Online, accessed May 8, 2012.

http://www.bcinvvasiveplants.com/iscbc/publications/TIPS/Highways_Operations_TIPS.pdf

Invading Species Awareness Program Workshop Manual: Aquatic Invasive Species: An Introduction to Identification, Collection and Reporting of Aquatic Invasive Species in Ontario Waters (includes information on decontaminating equipment).

<http://www.invadingspecies.com/download/publications/manuals/WorkshopManual.pdf>

Reporting Invasive Species

To report invasive species, or view maps of existing records, visit the Invading Species Awareness Program website www.invadingspecies.com/report/ or www.eddmaps.org/Ontario.

Or call the OFAH/MNR Invading Species Awareness Program Hotline at **1-800-563-7711**.

Acknowledgements

We gratefully acknowledge NRM South (Tasmania, Australia) for allowing the use of their artwork and text from their “Keeping it Clean – A Tasmanian Field Hygiene Manual to Prevent the Spread of Freshwater Pests and Pathogens”.

We also sincerely thank the Clean Equipment Protocol Working Group and the Ontario Invasive Plant Council Committees and Board of Directors for their ongoing support and valuable input into this document, and the Canada-Ontario Invasive Species Centre and Ontario Ministry of Natural Resources for the support in creating this protocol.

Clean Equipment Protocol Working Group:

Diana Shermet, Central Lake Ontario Conservation Authority; Paula Berketo, Ontario Ministry of Transportation; Travis Cameron, Ontario Ministry of Natural Resources; Jennifer Hoare, Ontario Parks; Michael Irvine, Ontario Ministry of Natural Resources; Alison Kirkpatrick, OFAH/MNR Invading Species Awareness Program; Erika Weisz, Ontario Ministry of Natural Resources; Amanda Chad, Ontario Power Generation; Nancy Vidler, Lambton Shores Phragmites Community Group; Nigel Buffone, Du Pont Canada Company; Ewa Bednarczuk, Lower Trent Conservation Authority

We also gratefully acknowledge the input and direction from Francine MacDonald, James Rockwood, Anne-Marie Roussy, Stephen Smith, Caroline Mach, Patricia Lowe, John Bowen, Karen Hartley, and the Southern Ontario Community Forest Managers group.

More Information:

Ontario Invasive Plant Council: www.ontarioinvasiveplants.ca

Appendix A: Identification of Invasive Plants Found in Ontario

- **Common Buckthorn** (*Rhamnus cathartica*) and **Glossy Buckthorn** (*Frangula alnus*)
- **Dog-strangling Vine** (*Cynanchum rossicum*)
- **Garlic Mustard** (*Alliaria petiolata*)
- **Japanese Knotweed** (*Polygonum cuspidatum*)
- **Phragmites or Common Reed** (*Phragmites australis subsp. australis*)
- **Giant Hogweed** (*Heracleum mantegazzianum*)

common & glossy buckthorn

(*Rhamnus cathartica* & *R. frangula*)



Plant type: Shrub/small tree

Arrangement: Common buckthorn are sub-opposite (almost opposite). Glossy buckthorn are alternate.

Leaf: The common buckthorn leaf is egg shaped, edge of the leaf is “pebbled” (small rounded teeth). Veins converging toward leaf top. The glossy buckthorn leaf is more slender (tear drop shaped) and smooth margined.

Bark: Smooth, young bark with prominent raised patches or lenticels; rough texture and peeling bark when mature.

Seed/Flowers: Flowers are green-yellowish, small and inconspicuous. Green berries becoming purplish/black in late summer, berry > 1 cm in diameter.

Buds/Twigs: Common buckthorn has thorn-like tip on many twigs. Glossy buckthorn buds have no bud scales and lack thorny tips to twigs.

Habitat: Various - forest, thickets, meadows, dry to moist soils.

Similar native species: Native dogwoods, which lack the thorny “tip”. Native dogwoods are truly opposite in arrangement of twigs; only alternate leaved (pagoda) dogwood has alternate branching.



dog-strangling vine

(*Cynanchum rossicum* & *C. nigrum*)



Plant type: Herb, twining vine

Arrangement: Opposite

Leaf: Lance shaped, smooth margin (edge)

Bark: n/a

Seed/Flowers: Bean shaped seed pod with seeds attached to downy 'umbrellas'. Flowers - pink (*C. rossicum*) or purple (*C. nigrum*) with five petals.

Buds/Twigs: n/a

Habitat: Dry to moist soils; more dominant in meadows and woodland edges.

Similar native species: Swamp milkweed (*Asclepias incarnata* spp.), is an upright plant, typically found in wetland habitats.

garlic mustard

(*Alliaria petiolata*)



Plant type: Herb

Arrangement: Alternate

Leaf: Saw tooth like edge, elongated heart shape. Garlic/onion smell when crushed. Leaves are kidney shaped with prominent veins.

Bark: n/a

Seed/Flowers: Cluster of small white flowers with four petals. Small black < 1 mm rounded seed found in elongated 'tube-like' seed pods (similar to a bean pod).

Buds/Twigs: n/a

Habitat: Various – dry to moist soils, in all habitat types, less often in meadows.

Similar native species: n/a

japanese knotweed

(*Polygonum cuspidatum*)



Plant type: Herb, 2 - 4 m in height.

Arrangement: Alternate

Leaf: Tear drop shaped, sharp pointed, dark green, flattened at base.

Bark: n/a

Seed/Flowers: Flowering stalk of many small greenish-white flowers.

Buds/Twigs: Large plant with a 'bamboo-like' stem. Stem light green maturing to tan colour.

Habitat: Moist to wet soils found in wetlands, water-courses and roadside ditches.

Similar native species: None.

common reed

(*Phragmites australis*)



Plant type: Grass

Arrangement: Alternate

Leaf: Broad leaf > 1 cm wide.

Bark: n/a

Seed/Flowers: Dense cascading 'broom-like' flower head. 'Cottony' in appearance when mature.

Buds/Twigs: Stems rough and ridged, ligule a densely hairy band. Mature plants > 3 m tall.

Habitat: Moist to wet soils. Found in wetlands, water-courses and road side ditches.

Similar native species: Species of mannagrass (*Glyceria* sp) including tall northern, eastern and rattlesnake grass. A native common reed exists but has a smooth stem and the ligule is not hairy. It is also quite rare.

giant hogweed

(*Heracleum mantegazzianum*)



Plant type: Herb. Mature plants can be over 3m tall.

Arrangement: Alternate

Leaf: Lobed leaf 1-2 m wide, lobes sharp-pointed.

Bark: n/a

Seed/Flowers: Small, white flowers in a large umbrella-shaped cluster, .75 m wide.

Buds/Twigs: Hairy stem with purple spots.

Habitat: Fresh to wet soils in forests, swamps, meadows, marshes.

Similar native species: Cow parsnip (*Heracleum maximum*) – has smaller flowers, no purple spots on stems. Angelica (*Angelica atropurpurea*) has a rounded-topped flower cluster and leaves divided into many leaflets.

Do not touch this plant because it is poisonous. If you do, wash your skin immediately in cool soapy water and do not expose the area to sunlight.

Seek professional advice before removing.

Identification of Invasive Plants found in Ontario Photos by:

Credit Valley Conservation, Greg Bales, Ken Towle, Patrick Hodge,
Ontario Federation of Anglers and Hunters, Francine Macdonald, Matt Smith

Appendix “G”

Best Management Practices Documents References/Additional Resources

Technical Guidelines

(Best Management Practices & Resource Material)

for the

Integrated Pest Management Plan

COUNTY OF RENFREW

Best Management Practices Documents Series

Common Buckthorn Best Management Practices for Ontario

Dog-strangling Vine Best Management Practices for Ontario

Garlic Mustard Best Management Practices for Ontario

Giant Hogweed Best Management Practices for Ontario

Phragmites (Common Reed) Best Management Practices for Ontario

Japanese Knotweed Best Management Practices for Ontario

Wild Parsnip Best Management Practices for Ontario

Invasive Honeysuckles Best Management Practices for Ontario

White Sweet Clover Best Management Practices for Ontario

European Black Alder Best Management Practices for Ontario

Additional Publications from the Ontario Invasive Plant Council

Clean Equipment Protocol for Industry

Compendium of Invasive Plant Management

Grow Me Instead! Beautiful Non-Invasive Plants for Your Garden, a guide for Southern Ontario

Grow Me Instead! Beautiful Non-Invasive Plants for Your Garden, a guide for Northern Ontario

References/Additional Resources

Averill, K., and A.M. DiTommaso. 2007. Wild Parsnip (*Pastinaca sativa*): A Troublesome Species of Increasing Concern. *Intriguing World of Weeds. Weed Technology* 21:279-287.

Cain, N., S.J. Darbyshire, F. Ardath, R.E. Nurse, and M.J. Simard. 2010. The Biology of Canadian Weeds. 144. *Pastinaca sativa* L. *Can. J. Plant Sci.* 90: 217-240.

Carroll, S.P. 2011. *Conciliation Biology: The Eco-Evolutionary Management of Permanently Invaded Biotic Systems. Evolutionary Applications, Blackwell Publishing Ltd.* 4: 184-199.

Gaertner, M., J.L. Fisher, G.P. Sharma, and K.J. Esler. 2012. Insights into invasion and restoration ecology: Time to collaborate towards a holistic approach to tackle biological invasions. *Neobiota* 12: 57-75.

Jacquart, E. 2009. Where do I start?! Prioritizing Invasive Plant Control. Indiana Chapter of The Nature Conservancy. Available at: <<http://www.inwoodlands.org/where-do-i-start-prioritizing/>> (Accessed November 5, 2012)

Kaufman, S. and W. Kaufman. 2007. *Invasive Plants: A guide to identification and the impacts and control of common North American species. Stackpole Books.*

Kennay, J and Fell, G. 2013. *Vegetation Management Guideline: Wild Parsnip (Pastinaca sativa L.). University of Illinois.* Available at: <<http://www.inhs.illinois.edu/research/vmg/parsnip>> (Accessed October 29 2013)

Krick, R., H. Anderson, G. Bales, F. Forsyth, E. Weisz, F. MacDonald, S. Bull, and R. Gagnon. 2012. *A Landowners Guide to Managing and Controlling Invasive Plants. Credit Valley Conservation.* 116 pp. Available at: <<http://www.creditvalleyca.ca/watershed-science/plants-animals-communities/invasive-species/resources/>> (Accessed September 18 2012)

Minnesota Department of Agriculture. 2013. Wild Parsnip. Available at: <<http://www.mda.state.mn.us/plants/badplants/noxiouslist/~media/Files/plants/weeds/wildparsnipbmp.ashx>> (Accessed January 14 2013)

Rask, A.M., and P. Kristoffersen. 2007. A Review of Non-chemical Weed Control on Hard Surfaces. *Weed Research* 47, 37

Appendix “H”

Public Service Announcement Public Education

Technical Guidelines

(Best Management Practices & Resource Material)

for the

Integrated Pest Management Plan

COUNTY OF RENFREW

COUNTY OF RENFREW MEDIA RELEASE

COUNTY OF RENFREW RESPONDS TO CONCERNS ABOUT WILD PARSNIP

05/31/16

PEMBROKE (ON): The County of Renfrew continues to be concerned with the spread of Wild Parsnip. Several inquiries were received in 2015 with regards to the presence of Wild Parsnip on public and private property and further calls are expected in 2016. Wild Parsnip (*Pastinaca Sativa*) is an invasive plant that is increasingly common within the County of Renfrew in areas of uncultivated land, roadside ditches, nature trails, as well as on and surrounding rural and residential properties.

Wild Parsnip may pose a health risk to humans. The plant sap contains chemicals that may cause skin and eye irritation and make the skin prone to burning and blistering when exposed to the sun. The blisters typically occur one to two days after contact with the plant. This can result in long-term scarring of the skin.

The best way to avoid contact with Wild Parsnip is to become familiar with what the plant looks like so you do not accidentally come in contact with the plant.

Wild Parsnip is a highly branched plant, with hollow green stems. It has two growth stages: non-flowering leafy rosettes at ground level and 0.5 to 1.5 metre-tall yellow flowering plants. In the first year of growth, low-growing non-flowering rosettes of leaves form with a cluster of spindly, compound leaves that resemble celery leaves. Second and third year plants have tall, branched flowering stalks that usually bloom in early June to late July. Seeds are flat and round. It is a biennial plant, reproducing only by seed. The seeds can lie dormant for years making it even more challenging to control.

Further information about Wild Parsnip can be obtained from:

<http://www.invadingspecies.com/invaders/plants-terrestrial/wild-parsnip/>

http://www.omafra.gov.on.ca/english/crops/facts/ontweeds/wild_parsnip.htm

Jason Davis, Area Weed Inspector for the County of Renfrew shared this message, "Residents are encouraged to become familiar with Wild Parsnip and its effects and should take measures to protect themselves. County staff continue to respond to reports of Wild Parsnip and other noxious plants."

For more information, questions or concerns please do not hesitate to contact:

Jason Davis, Area Weed Inspector, County of Renfrew 613-735-3204 ext 463;
jdavis@countyofrenfrew.on.ca

Michael Barber Media Relations/ Grants Coordinator, County of Renfrew 613-735-7288

14/06/2016

Pembroke Daily Observer e-edition - The Daily Observer - 14 Jun 2016 - Page #4

County concerned over continuing spread of wild parsnip

The County of Renfrew continues to be concerned with the spread of wild parsnip. Several inquiries were received in 2015 with regards to the presence of wild parsnip on public and private property and further calls are expected in 2016.

Wild parsnip (*Pastinaca Sativa*) is an invasive plant that is increasingly common within the county in areas of uncultivated land, roadside ditches, nature trails, as well as on and surrounding rural and residential properties.

Wild parsnip may pose a health risk to humans.

"Residents are encouraged to become familiar with wild parsnip and its effects and should take measures to protect themselves," said Jason Davis, area weed inspector for the County of Renfrew. "County staff continue to respond to reports of wild parsnip and other noxious plants."

The plant's sap contains chemicals that may cause skin and eye irritation and make the skin prone to burning and blistering when exposed to the sun. The blisters typically occur one to two days after contact with the plant. This can result in long-term scarring of the skin.

The best way to avoid contact with wild parsnip is to become familiar with what the plant looks like so you do not accidentally come in contact with the plant.

Wild parsnip is a highly branched plant, with hollow green stems. It has two growth stages, non-flowering leafy rosettes at ground level and 0.5 to 1.5 metre-tall yellow flowering plants. In the first year of growth, low-growing non-flowering rosettes of leaves form with a cluster of spindly, compound leaves that resemble celery leaves. Second and third year plants have tall, branched flowering stalks that

usually bloom in early June to late July. Seeds are flat and round. It is a biennial plant, reproducing only by seed. The seeds can lie dormant for years making it even more challenging to control.

Residents that have a small infestation in a yard or garden (fewer than 100 plants), or who do not want to use pesticides, can dig out as much of the taproot as possible with a sharp shovel or spade. Follow-up digging will be required every few weeks to deal with re-growth (if the taproot was not completely removed) or missed plants. Do not burn or compost wild parsnip plants that have been cut down or dug up. Plants and roots that have been removed should be placed in a dark plastic bag and placed in the sun if possible away from areas where children or pets could access them. After the wild parsnip plant has been left in a black bag for one to two weeks in the sun, it can be collected through your normal waste collection as garbage, not as leaf or yard waste. Wear goggles and protective clothing when digging.

Mowing can be effective if begun just after peak blooming, but before the seeds set in the late summer or early fall. Cut plants will likely re-sprout after mowing, so it is important to combine mowing with other control methods such as bagging and removing the plants, especially those that are flowering and spot spraying with an approved herbicide. Be especially careful when using mowers, weed whips, mechanical string trimmers as they can



POSTMEDIA NETWORK FILE PHOTO
Wild parsnips are a health menace along local roadsides and trails.

spray users with sap and bits of the plants, leading to redness and sometimes hundreds of blisters on exposed skin. Wear goggles and protective clothing when mowing.

When a weed such as wild parsnip is declared a noxious weed residents are able to purchase herbicides to control it. This is not considered a cosmetic use of pesticides because this plant can pose a risk to people. For more information please go to: www.ontario.ca/page/pesticides-home-lawns-and-gardens

Further information about wild parsnip can be obtained from: <http://www.invasivespecies.com/invasives/plants-terrestrial/wild-parsnip/>
http://www.omafra.gov.on.ca/english/crops/facts/ontweeds/wild_parsnip.htm

2015 Education & Awareness Campaign

- Conducted an education and public health awareness campaign



WILD PARSNIP AVOID IT!

The sap from Wild Parsnip leaves, stems and flowers can cause severe skin irritation and make the skin prone to severe burning and blistering when exposed to the sun. It is commonly found along unmaintained rural and suburban roadsides and pathways, but can grow anywhere weeds are found.

THIS IS WHAT WILD PARSNIP LOOKS LIKE:



EARLY GROWTH



IN BLOOM



MATURE PLANT

For information on reporting it on City property and ways to remove it on your own property, go to www.ottawa.ca/wildparsnip or call 3-1-1.



ottawa.ca
3-1-1 
TTY 613-580-2401